



CE

GB

OPERATING MANUAL

OPTIMUS 2 / - 2S

Model 2.322

MEYRA[®]
ORTOPEDIA

We move people.

Contents

Introduction	6
Indications	7
Specifications	7
Acceptance	7
Use	8
Adjustment	8
Life span	9
Overview	10
Model: 2.322	10
Handling the electric wheelchair	11
Securing the electric wheelchair	11
Functional checks	11
Driving behaviour.....	11
Brakes	11
Operating brake	11
Braking the electric wheelchair	11
Drum Brake	12
Locking the brake	12
Releasing the brake	12
Drive-/push mode	13
Selecting the push mode	13
Selecting the motor mode	13
Selecting the operation	14
Pre-operation checks.....	16
Battery charging procedure	16
Positioning the operating module.....	17
Function description	17
Adjusting the distance to the padded arm support	17
Removing the operating module	17
Inserting the operating module	17
Swivelling the operating module	18
Height adjustment of the operating module.....	18

Leg supports	19
Calf belt.....	19
Removing the calf belt	19
Attaching the calf belt.....	19
Length adjustment of the calf belt.....	19
Leg support lower part	20
Footplates	20
Footboard	20
Leg support upper part.....	21
Turning the leg supports to the side	21
Swivelling in the leg supports.....	22
Removing the leg supports	23
Attaching the leg supports	23
Mechanically height-adjustable leg supports	24
Lifting/lowering the leg support	24
Electrically height-adjustable leg support.....	25
Height adjustment	25
Removing the electrically height adjustable leg support.....	26
Hanging the electrically height adjustable leg support into place	26
Arm supports, code 106.....	27
Remove the arm support.....	28
Arm supports code 24 - Ergostar seat.....	29
Swivel up the arm supports.....	29
Adjusting the angle of the arm support	29

Seat	30
Swivelling up the seat.....	30
Electrical seat-angle adjustment.....	30
Seat Ergostar.....	31
Adjustment of the back support angle.....	31
Lordosis adjustment.....	31
Ergo Seat.....	32
Folding over the back support.....	32
Folding up the back support.....	32
Adjusting the back support angle.....	32
Electrically adjustable back support.....	33
Folding down the electrically adjustable back support.....	33
Unfolding the back support.....	33
Retaining strap	34
Head support	35
For seating system ERGO Seat	35
For seating system RECARO	35
Rear-view mirror	36
Removing the rear-view mirror.....	36
Attaching the rear-view mirror.....	36
Adjusting the rear-view mirror.....	36
Loading and transportation	37
Loading.....	37
Person transport inside a motor vehicle.....	37
Transport security.....	38

Maintenance	38
Maintenance	38
Maintenance schedule.....	39
Fuses	41
Replacing the fuses	41
Tyre damage on pneumatic tyres.....	41
Lighting	42
Adjusting the headlights.....	42
Fault correction	43
Technical data	44
Kilometric performance.....	44
Hill climbing ability	44
Technical data	45
Model 2.322	45
Meaning of the labels on the electric wheelchair.....	50
Meaning of the symbols on the type plate.....	51
Inspection certificate	52
Notes.....	53
Warranty / Guarantee.....	54
Warrantee / Guarantee section.....	55
Inspection certificate for transfer	55

INTRODUCTION

We thank you for the confidence you have placed in our company by choosing an electric wheelchair from this series.

With all equipment and their accessories the electric wheelchair offers the respective adaptation to your disability.

Like any other vehicle, an electric wheelchair is a technical aid. It is subject to explanations, requires regular care and can cause danger when used improperly. The correct handling must therefore be learned. This operating manual is to help you get accustomed to the handling of the electric wheelchair as well as to prevent accidents.

Note:

Please note that the illustrated equipment variants can deviate from your model.

We have therefore also listed chapters with options that might not be applicable for your vehicle.

Attention:

-  Read and observe the following
- documentation belonging to the electric wheelchair before first use:
 - this operating manual,
 - the operating manual < *Operating module* > ,
 - the safety and general handling instructions < *Electronic vehicles* > .

Note:

Children and juveniles should read the documentation belonging to the electric wheelchair together with their parents respectively a supervisor or accompanying person before first use.

Users with visual impairments can find the PDF-files of above mentioned documents on our website under:

< www.meyra-ortopedia.com > .

Alternatively users with visual impairments can have the documentation read out by a helper.

Additional information about our products can be found on our website:

< www.meyra-ortopedia.com > .

 Contact your specialist dealer when required.

INDICATIONS

If the following indications occur we recommend the application of this mobility product:

- ☞ Walking disability resp. extremely limited walking ability as part of the basic need to move around in your own home.
- ☞ The need to be able to leave home for a short walk in fresh air or in order to reach the places, commonly in the perimeter of the home, required to fulfil basic needs.

SPECIFICATIONS

The electric wheelchair is an environment-friendly electronic vehicle. It was developed to extend the mobility of persons with health-related or age-related restrictions.

- ☞ The model is assigned to user category B (Optimus 2) resp. C (Optimus 2 S) according to the norm EN12184.

ACCEPTANCE

All products are checked for faults in the factory and packed in special boxes.

☞ **Note:**

However, we request that you check the vehicle for possible transport damage immediately on receipt – preferably in the presence of the carrier.

☞ **Note:**

The packaging of the electric wheelchair should be stored for a further transport that might become necessary.

USE

The electric wheelchair, with attached leg supports and arm supports, serves exclusively for the conveyance of one sitting person. Other pulling or transporting uses do not comply with its intended purpose.

This model is an electric wheelchair especially for indoor and outdoor use on firm, level surfaces.

The electric wheelchair offers manifold adjustment possibilities to individual vital statistics.

The electric wheelchair should be adapted to your needs by a specialist dealer before the first use. The adaptation will take into account the driving experience, the physical limits of the user and the main place of use of the electric wheelchair.

Attention:

- ! Always have adaptation and adjustment work carried out by a specialist dealer.

ADJUSTMENT

The specialist workshop will hand out the electric wheelchair to you under consideration of all relevant safety instructions, ready for operation and adjusted to your needs.

Note:

- ☞ We recommend a regular inspection of the electronic wheelchair adjustment in order to ensure a long-term optimal provision even with changing illness/handicap patterns of the user. Especially for children and juveniles an adjustment every 6 months is recommendable.
- ☞ We recommend regular medical exams in order to ensure safety for active participation in traffic.
- ☞ Retrospective adjustments should be carried out solely by the specialist dealer!

LIFE SPAN

We expect an average lifespan of about 5 years for this product, as far as the product is applied for its designated purpose and all maintenance and service guidelines.

The life span of your product depends upon the frequency of use, the application environment and care.

The implementation of spare parts can prolong the life span of the product. As a rule spare parts are available up to 5 years after production is discontinued.

☞ The indicated life span does not constitute additional guarantee.

OVERVIEW

Model: 2.322

The overview shows the most important components and operating devices of the electric wheelchair.

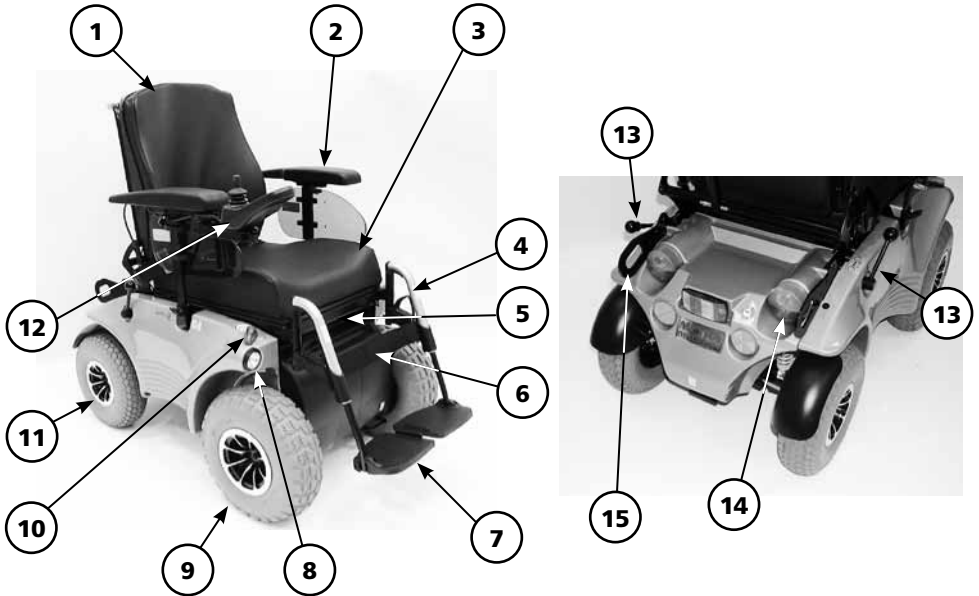

Pos. Description

- | | | | |
|----|------------------|----|---|
| 1 | Back support | 13 | Selection lever drive/push mode resp. brake lever |
| 2 | Arm support | 14 | Direction indicator light / back light |
| 3 | Seat | 15 | Rear transport attachment |
| 4 | Leg support | | |
| 5 | Seat lock | | |
| 6 | Calf belt | | |
| 7 | Footplate | | |
| 8 | Headlight | | |
| 9 | Drive wheel | | |
| 10 | Front indicator | | |
| 11 | Steering wheel | | |
| 12 | Operating module | | |

HANDLING THE ELECTRIC WHEELCHAIR

Securing the electric wheelchair

The electric wheelchair is to be secured as follows to prevent it from rolling off unintentionally:

1. Switch the selection lever for drive-/push mode up to drive mode on both sides.
2. Switch the operating module off.

Functional checks

The functions and safety of the electric wheelchair must be checked before the start of each journey.

☞ For this observe chapter < *Inspections before starting to drive* > in the accompanying documentation.

Driving behaviour

You define the speed and direction yourself with the joystick movements (driving and steering lever) while driving as well as the pre-adjusted maximum final speed of your electric wheelchair.

BRAKES

Operating brake

The motors work electrically as operating brake and carefully brake the electric wheelchair down without jerks to stillstand.

Braking the electric wheelchair

For allotted braking of the electric wheelchair slowly guide the joystick back to the centre position (zero-setting).

☞ The electric wheelchair stops in shortest distance after releasing the joysticks.

Drum Brake

The optional drum brake only serves as a parking brake, resp. emergency brake.

The brake lever to engage the drum brake is located on the same side as the operating module.

Locking the brake

In order to engage the brakes, swivel the brake lever toward the back as far as possible [1].

Attention:

- ! The electric wheelchair may not let itself be pushed when the brake is activated.
- The brake performance reduces with the wear on the brake pads.

With reducing brake function immediately have the electric wheelchair serviced in a specialist workshop.

Releasing the brake

In order to disengage the brakes, swivel the brake lever toward the front as far as possible [2].

Attention:

- ! Entering resp. exiting the electric wheelchair may only be conducted with the electric wheelchair switched off and the brakes engaged.
- Inadvertently knocking the joystick will set the electric wheelchair in motion without control! – Danger of accidents!



Drive-/push mode

The Selection lever drive/push mode is located on the side opposite to the operating module.

Attention:

- ! Only switch the electric wheelchair to push mode when it is standing still for positioning or in case of emergencies, but not on slopes/hills.
- ☞ The electromagnetic brake is switched off when push mode is activated.
 - A braking of the electric wheelchair is then only possible by switching to the drive mode.
- ☞ For shunting the electric wheelchair grab hold on the push bar of the back support or the back support itself.

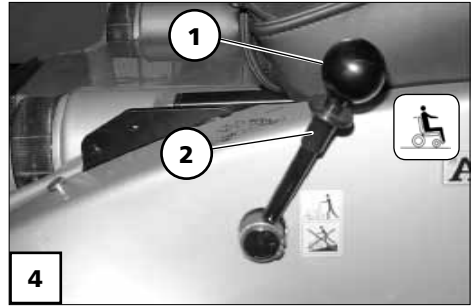

Selecting the push mode

1. Switch off the operating module because the pushing will otherwise be made difficult by the electric system.
 - ☞ Observe the operating manual < Operating module >.
2. First pull up the locking sleeve (2) on the selection lever drive/push mode, then guide the selection lever toward the back [3].
 - ☞ The electric wheelchair can now be pushed.

Selecting the motor mode

1. Guide the selection lever drive/push mode forward and let it audibly lock into place [4].
2. Switch the operating module on.

- ☞ Observe the operating manual < Operating module >.
- ☞ The electric wheelchair is now ready for operation again.

SELECTING THE OPERATION

In order to obtain operational readiness of the electric wheelchair the following directions are to be carried out in the indicated order.

👉 **Note:**

Charge the drive batteries via the operating module before the first journey.

1. Establish drive mode

Switch the selection lever drive/push mode to drive mode. – Push the selection lever to the front [1] until it audibly latches.

👉 Observe chapter < *Drive/push mode* >.

2. Loosen the drum brake

Swivel the brake lever forward as far as possible [2].

👉 Observe chapter < *Drum brake* >.



3. Checking the position of the operating module

The operating module should be positioned in such a way that you can comfortably and safely steer the electric wheelchair.

Adjusting the distance to the padded arm support:

The distance of the operating module to the padded arm supports can be adjusted after loosening the clamping screw (1).

Attention:

! After the adjustment retighten the
● clamping screw.

☞ Therefore observe chapter < *Positioning the operating module* >.

Height adjustment

☞ Therefore observe chapter < *Positioning the operating module* >.

4. Switch the operating module on

Press the ON/OFF-key (2) on the control panel of the operating module.

☞ Observe the operating manual < *Operating module* >.

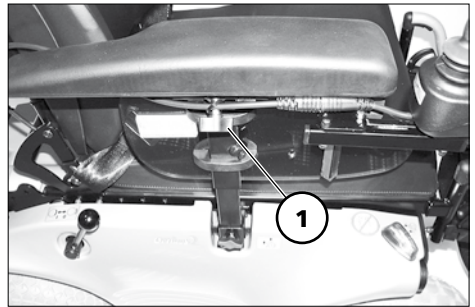
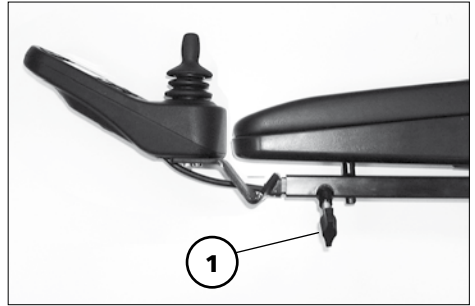

Pre-operation checks

Before starting to drive, the following should be checked:

- ☞ the battery charging condition,
- ☞ the setting of the preselected final speed.
- For this observe the operating manual < *Operating module* >.

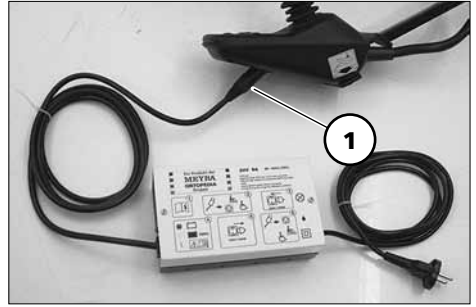

Battery charging procedure

- ☞ For the battery charging procedure also observe the operating manual of the battery charger.
1. Lock the electric wheelchair.
 - ☞ Therefore observe chapter < *Securing the electric wheelchair* >.
 2. Insert the battery charger plug into the operating module (1).

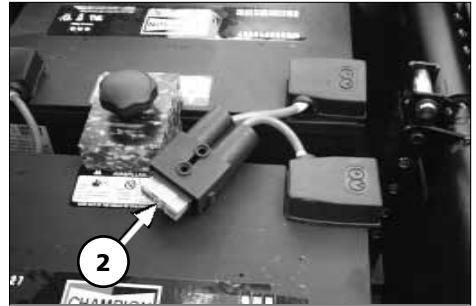

Attention:

- ! Do not insert any objects other
 - than the battery charger plug into the battery charging socket.
 - Danger of short circuit!
3. Switch the battery charger on, resp. insert the main plug of the battery charger into the corresponding power socket.
 - The battery charging procedure is initiated.
 - ☞ The charging procedure only runs with an intact mains/battery fuse (2)!
 4. After a completed charging procedure disconnect the battery charger from the socket and remove the battery charging plug from the battery charging socket.

Positioning the operating module

Function description

You will find a detailed description of the keys and symbols in the operating manual for < *Operating module* >.

The position of the operating module can be adjusted to suit the individual size of the user. The operating module can also be removed for transportation or storage and can be laid on the seat or stored separately.

Attention:

- ! Switch off the operating module
- before adjusting/removing it.

Adjusting the distance to the padded arm support

Slacken the clamping screw distance adjustment (1). Afterwards slide the operating module into the desired position. In doing so carefully guide the cable and retighten the clamping screw (1) securely.

Removing the operating module

In order to remove the operating module loosen the clamping screw (1) and disconnect the plugged connection (2) (4).

- ⚠ Do not pull on the cable while doing so.

Afterwards pull out the operating module toward the front out of the arm support tube.

Inserting the operating module

For drive mode insert the operating module from the front into the arm

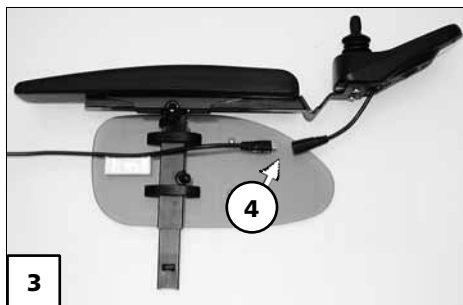
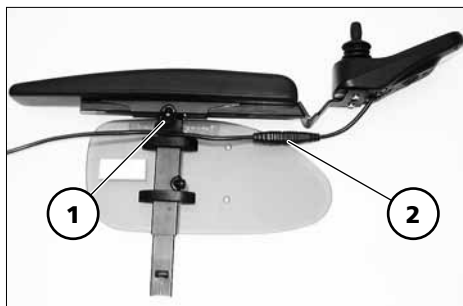

support tube [3] and adjust the distance to the padded arm support.

- ⚠ Therefore observe chapter < *Adjusting the distance to the padded arm support* >.

Afterwards re-establish the plugged connection (4) (2).

- ⚠ The plugged connection must audibly lock into place. – Afterwards check the function of the operating module.

Swivelling the operating module

With the optional swivel away operating module adapter [1] the operating module can be swivelled back to the side (2) so that it is located parallel to the arm support. This makes it possible, for example:

- to drive closer to a table,
- remove the operating module more easily.

For regular drive mode the operating module can be swivelled back toward the front until it engages back into the magnetic lock [1].

Note:

 The power of the magnets (3) can be reduced, for example with tape on top of the magnets, for easier swivelling of the operating module.

 Should the operating module be positioned too close to the arm support, move it forward before swivelling.

Attention:

-  Do not grab into the area of the cross brace. – Danger of jamming!

Height adjustment of the operating module

Loosen the clamping screw (4) to adjust the height of the operating module.

Attention:

-  After the adjustment retighten the clamping screw.

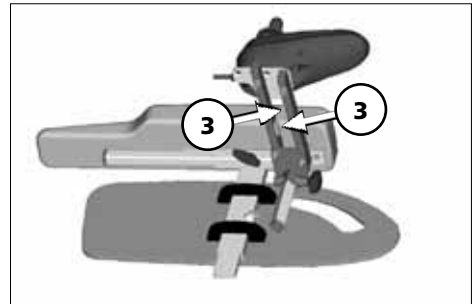
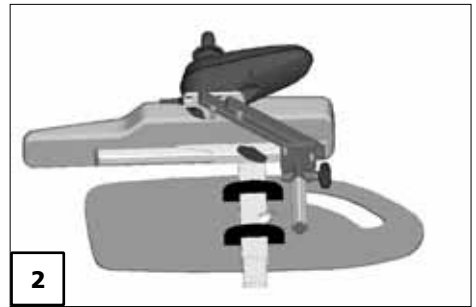
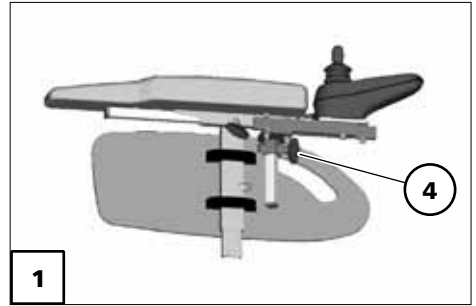

LEG SUPPORTS

Attention:

- ! Before any actions on the leg supports the wheelchair is to be secured against unintentional rolling motions.

☞ Therefore observe chapter < *Securing the electric wheelchair* >.

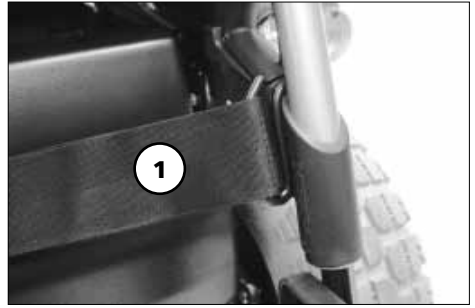

Calf belt

The removable calf belt (1) prevents the feet from sliding off the back of the footplates.

Attention:

- ! Do not drive without the calf belt.
- – Danger of accidents!

Note:

The calf belt must be removed in order to swivel away the leg supports [2].

- ☞ The calf belt is omitted for height adjustable leg supports and is replaced by a calf pad.

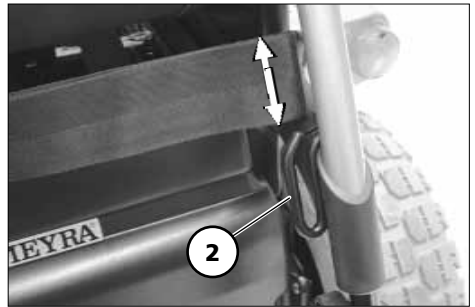

Removing the calf belt

For removal the calf belt is to be pulled from the attachment pins (3).

Attaching the calf belt

For attachment both loops of the calf belt are slid over the attachment pins [4].

Length adjustment of the calf belt

For length adjustment, the calf belt is guided around the special attachment pins (2) and adjusted in length with a velcro fastener.

Leg support lower part

The footplates, resp. footboard needs to be folded up before entry or exit [1].

- ☞ Check the locking points!
- Remove both feet from the footplates.
- Fold both footplates up toward the side [1].

☞ **Note:**

Before starting to drive the footplates resp. the footboard is to be folded down again [2].

Footplates

The footplates can be folded outward and up [1] resp. inward and down [2].

Footboard

Fold the footboard up before swiveling away and removing the upper leg support.

Folding up the footboard

In order to fold up the footboard lift the loose end of the footboard [4] as far as possible.

Folding the footboard down

In order to fold down the footboard, lower the loose end of the footboard as far as possible down onto the footboard bracket (5).

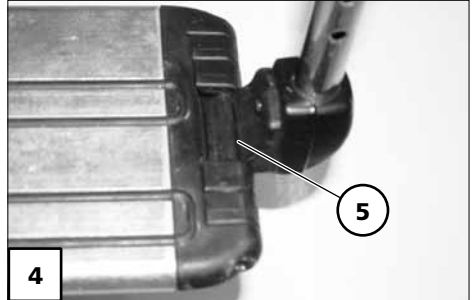

Leg support upper part

The upper leg support with an inserted lower leg support is termed leg support.

Turning the leg supports to the side

To reduce the length of the electric wheelchair the leg supports can be swivelled inward/outward [1]+[2].

Note:

Remove the calf belt before swivelling away the leg supports.

 Hereto observe chapter < *Calf belt* >.

Attention:

 Leg supports turned to the side are released automatically and can easily come off. Note this when handling (e.g. transport).

– Fold up the footplates resp. footboard in order to swivel away the leg supports.

 Hereto observe chapter < *Leg support lower part* >.

– Afterwards pull or press the respective locking lever (3) backward and swivel the corresponding leg support outward.

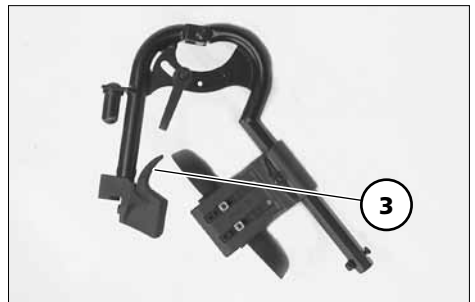
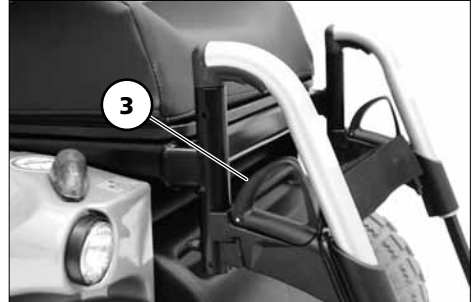

Swivelling in the leg supports

For inward swivelling, let the leg supports swivel forward until the lock audibly engages [1].

Note:

After audibly swivelling the leg supports inward check the respective locking device.

 Afterwards observe chapter < *Lower leg support* >.



Removing the leg supports

For easy transfer into and out of the electric wheelchair as well as a reduced wheelchair length (important for transport) the leg supports can be removed [1].

Note:

Remove the calf belt before swivelling away the leg supports.

 Hereto observe chapter < *Calf belt* >.

- For removal first swivel the leg support sideways and then remove them toward the top [1].

 Therefore observe chapter < *Swivelling away leg supports* >.

-  Watch for possible danger of jamming!



Attaching the leg supports

- For inserting press the leg supports, swivelled to the side, parallel to the front frame tube and lower it into place [2]. – In doing so the holding pin must slide into the frame tube.

Note:

After attachment swivel the leg supports inward [3].

 Therefore observe chapter < *Swivelling in the leg supports* >.



Mechanically height-adjustable leg supports

Attention:

- ! Never put the free hand into the adjustment mechanism while adjusting the height adjustable leg support. – Danger of crushing!
- Have the leg support that is to be adjusted secured against falling away by an accompanying person.

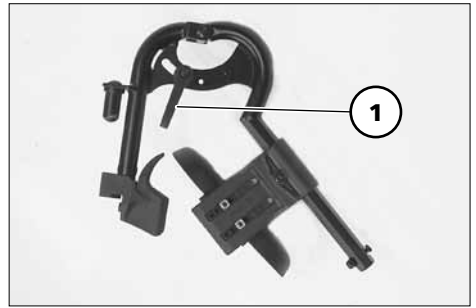

Lifting/lowering the leg support

1. Before lifting/lowering relieve the leg support by an accompanying person by slightly lifting it up.
2. Afterwards loosen the clamping lever (1) and have the leg support lifted/lowered slowly to the desired level by an accompanying person.

Attention:

- ! Do not let the leg support drop on its own weight. – Danger of injury!
3. After the adjustment retighten the clamping lever (1) securely.

Electrically height-adjustable leg support

The electrically height adjustable leg support [1]+[2] automatically receives electric contact when hooked on.

Attention:

- ! Never put the free hand into the adjustment mechanism while adjusting the height adjustable leg support. – Danger of crushing!

Height adjustment

–For height adjustment, raise or lower the leg support to the desired height via the operating module [1]+[2].

- 📖 Observe the operating manual < *Operating module* >.

Attention:

- ! Observe the safety and general handling instructions < *Electronic vehicles* >!



Removing the electrically height adjustable leg support

To remove the leg support, first pull or press the locking lever (1) to the back. Afterwards swivel the leg support sideways and remove it toward the top [2].

☞ Therefore observe chapter < *Swivelling away leg supports* >.

Attention:

- ! When the electrically height adjustable leg supports are removed the electric contact (3) needs to be protected from dampness, water and dust or dirt (e. g. for longer storage)!

– Possible function error of the electrical adjustment.

☞ For protection you can for example use the optional cover cap.

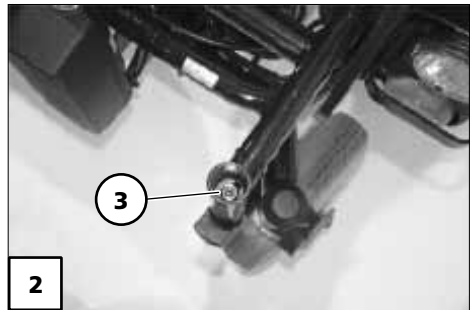

Hanging the electrically height adjustable leg support into place

☞ Note:

After attachment swivel the leg supports inward.

☞ Therefore observe chapter < *Swivelling in the leg supports* >.

- Press the leg supports, swivelled to the side, parallel to the front frame tube and lower it into place.
 - In doing so the holding pin must slide into the frame tube (1).

☞ Conduct a function test on the electrically height adjustable leg support!

ARM SUPPORTS, CODE 106

The removable arm supports [1]+[2] can be adjusted in height to the demands of the user.

Attention:

- ⚠ Do not use the arm supports to lift or carry the wheelchair.
- Do not drive without the arm supports!
- Ensure the tight fit of the clamping screw (3) in order to prevent the arm support from sliding down.

👉 Note:

Danger of jamming when adjusting the height of the arm supports if the cushions are in a deep setting!

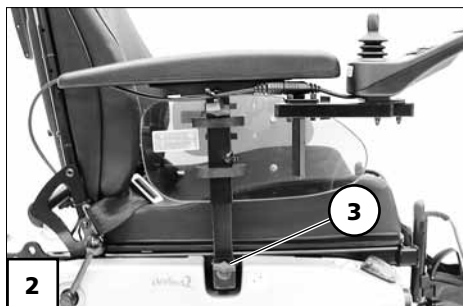

Remove the arm support

- Remove the arm support in an upwards direction [5]. – Therefore loosen the clamping screw (4) of the clamping guide.

 **Note:**

The operating module must be removed first if the arm support on the control side is to be detached.

To remove the operating module, loosen the respective clamping screw (6).

 **Note:**

Carefully route the cable when doing this.

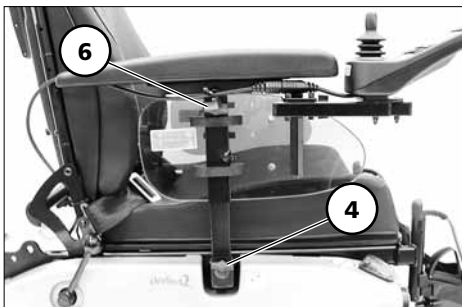

Arm supports code 24 - Ergostar seat

Swivel up the arm supports

The arm supports can be swivelled up for an easier transfer to/from the seat [1].

Adjusting the angle of the arm support

By turning the adjustment wheel (2) the angle of the arm support can be adjusted.

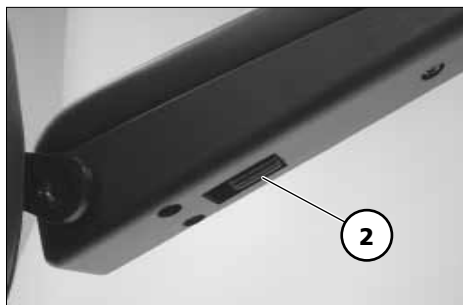

SEAT

Swivelling up the seat

Note:

- Remove the leg supports if necessary.
- Always remove the electrical leg supports.
- Grab under the front edge of the seat pad for upward swivelling.

Attention:

- Do not hold onto the leg supports to swivel the seat up!
- To swivel the seat upward, first press the seat locking lever upward (1) then swivel the seat unit toward the back and up [2].

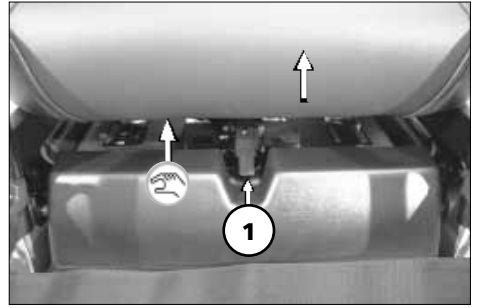

Electrical seat-angle adjustment

For the electrical seat angle adjustment also view the operating manual < *Operating module* >.

Attention:

- Do not grab into the adjustment area. – Danger of crushing!
- Observe the safety and general handling instructions < *Electronic vehicles* >!

Seat Ergostar

Adjustment of the back support angle

To adjust the angle of the back support the locking lever (2) must be pressed downward.

Let the locking lever latch at the next latching position after having adjusted the back support angle [1].

Note:

Check the lock of the back support.

Lordosis adjustment

To adjust the lordosis support turn the handwheel (3) counter-clockwise into the desired position.

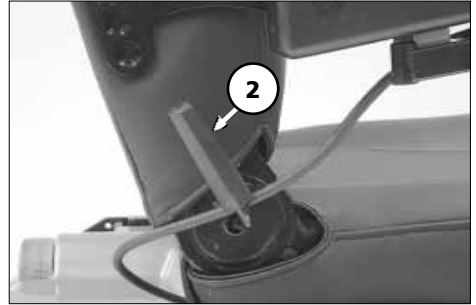

Ergo Seat

The back support can be folded down for storage or transport.

Note:

For better demonstration of the wire cable (1) the back support is shown without cushion.

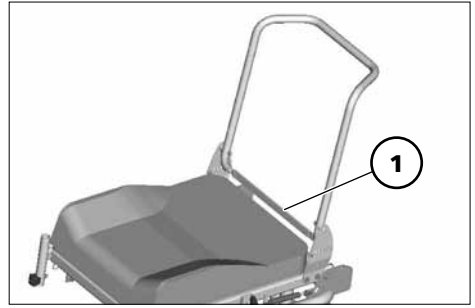

Folding over the back support



- If required remove the seat pad (velcro fastener).
- Disengage the back support by pulling or pressing the wire cable (1) at its centre and fold it onto the seat (2).

Folding up the back support

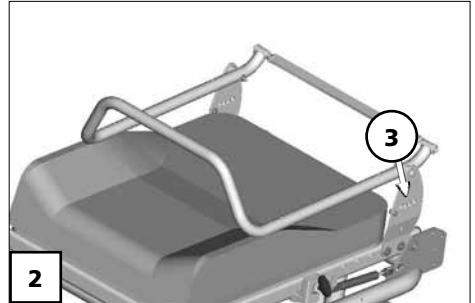
- For this raise the back support and pull the pressure bolts inward by pulling or pressing on the wire cable (1).
- Release the wire cable in order to lock the back support in the desired position (3). – The pressure bolt must audibly lock into place.
- If required replace the seat pad.



Note:

-  The greasing of the thrust bolts is recommended for an easier latching of the back support.
-  Check the lock of the back support.

 Check the lock of the back support.

Adjusting the back support angle

- Unlock the back support by pulling or pressing the centre of the wire cable (1).
- Release the wire cable in order to lock the back support in the desired position (3). – The pressure bolt must audibly lock into place.



Electrically adjustable back support

The back support [1] is electrically adjustable.

Note:

Herefore view the operating manual < *Operating module* >.

Attention:

-  Only adjust the back support when
-  the electric wheelchair is standing on a level surface. A danger of tipping over exists on gradients!

Folding down the electrically adjustable back support

To fold the electrically adjustable back support [2] down, first press the release button (3), then remove the pin (4).



-  Keep the back support in position with one hand at the push bar.

Afterwards fold the back support down [2].

-  Reinsert the pin (4) in order to prevent loss.

Unfolding the back support

After raising the back support [1] remove the pin (4), lift the gas pressure spring and hang it into place. The reinsert the pin (4).

-  Check the locking device after raising the back support up and reinserting the pin.
-  Keep the pin clean at all times for flawless function.

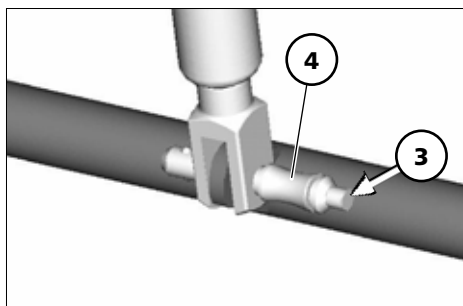
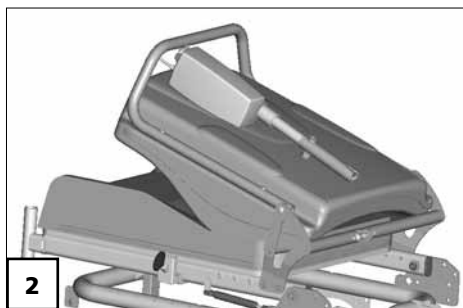
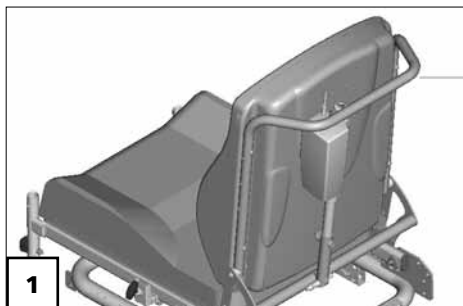

RETAINING STRAP

The retaining strap serves to strap in a person sitting in the electric wheelchair.

- Additional stabilisation of the sitting position.
- Prevents the user from sliding forwards out of the electric wheelchair.
- Continuous adjustment to suit the user's needs.

Attention:

- ! Make sure that no objects are trapped between belt and the body! – Thus you avoid painful pressure points.

The retaining strap is screwed on, from the outer side, at the respective back support holder (1).

Note:

The retrospective assembly of a retaining strap is only to be carried out by a specialist workshop!

Attention:

- ! The retaining strap is not part of the retaining system for the electric wheelchair and/or the driver during transport in motor vehicles.

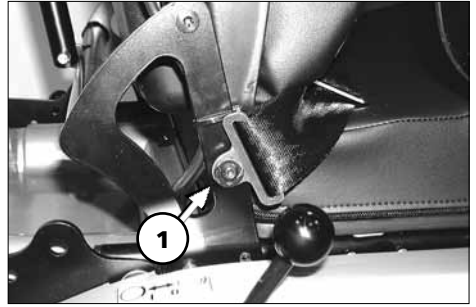

HEAD SUPPORT

The head support is swivel/proof, height- and depth adjustable and removable.

Attention:

- ! We recommend the fitting of two rear-view mirrors for driving with a head support.



For seating system *ERGO Seat*

The head support can be detached or adjusted in height after the clamping lever (1) has been slackened.

Attention:

- ! The maximum height adjustment is indicated by the marking!

For seating system *RECARO*

The head support can be adjusted in height by sliding it up or down.

- ☞ After opening the lock (2) push or pull the head support to the next engagement point.

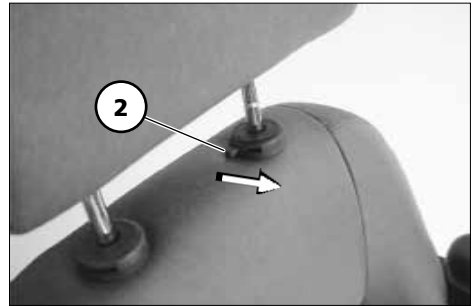

REAR-VIEW MIRROR

Removing the rear-view mirror

To remove the rear-view mirror loosen the clamping screw (2) and pull the rear-view mirror forward out of the arm support tube.

Note:

Carefully place the rear-view mirror down and protect the mirror glass from strain or other objects.

-  The rear-view mirror is to be kept clean at all times.
 - Use common glass cleanser to clean the mirror. For this the users instructions of the manufacturer are to be observed.

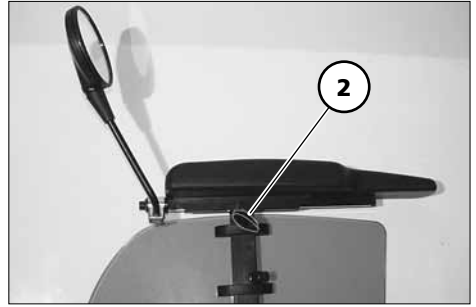

Attaching the rear-view mirror

For drive mode insert the rear-view mirror from the front into the arm support tube and tighten the clamping screw (2).

Adjusting the rear-view mirror

1. Preadjust the rear-view mirror by turning the clasp.
2. Turn the rear-view mirror on the attachment rod and ball joint until you reach the desired angle.

LOADING AND TRANSPORTATION

- ☞ Do not use the back support, leg supports, arm supports or restraints to lift the electric wheelchair!

Attention:

- ! The electric wheelchair must be switched off before lifting!

Loading

The electric wheelchair can be loaded with the aid of ramps or lifting platforms.

☞ Note:

Observe safety and general handling instructions < *Electronic vehicles* > chapter < *Ramps and lifting platforms* >.

Person transport inside a motor vehicle

To determine if your electric wheelchair is approved as a seat for person transport inside a motor vehicle, please look at the type plate of your wheelchair.

☞ Note:

Observe the guideline < *Safety with Meyra-Ortopedia-wheelchairs, also during transport in motor vehicles* >! – This document and further information can be accessed on our website < www.meyra-ortopedia.com > in the < Download Archive >.

Transport security

The electric wheelchair is only to be secured through the securing points (1) and (2).

- ☞ The anchor positions are marked with the symbol (3).
- ☞ The procedure for securing the electric wheelchair can be read in the document < *Safety and general handling instruction electronic vehicles* > chapter < *Transport in motor vehicles or conveyors* > .

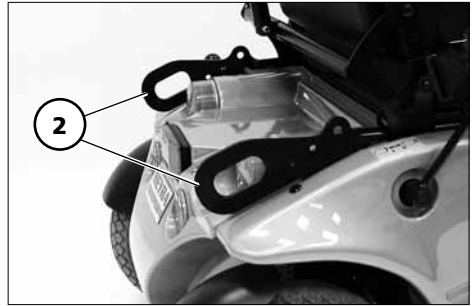
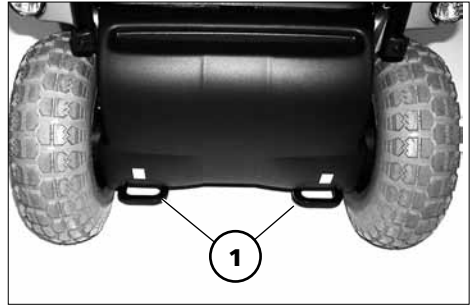

MAINTENANCE

An incorrect or neglected cleaning and maintenance results in a limitation of the product liability.

Maintenance

The following maintenance schedule gives you a guide for carrying out the maintenance.

- ☞ They do not give information about the actual extent of work required on the vehicle.

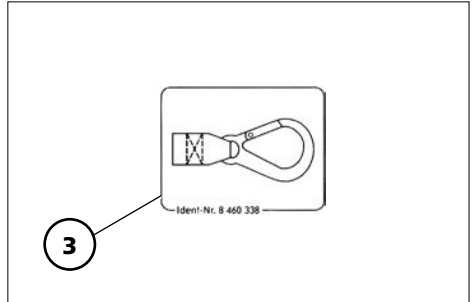

Maintenance schedule

WHEN	WHAT	REMARK
Before starting out	General Test for faultless operation.	Carry out test yourself or with a helper.
	Checking the magnetic brake Move the selection lever for the drive/push mode into the drive mode position on both sides.	Carry out test yourself or with a helper. If the electric wheelchair can be pushed, have the brakes repaired immediately by the specialist workshop. – Danger of accidents!
Especially before driving in the dark	Lighting Check the lighting equipment and reflectors for flawless functioning.	Carry out test yourself or with a helper.
Every 2 weeks (depending on distance covered)	Check air pressure of the tyres Tyre filling pressure: 2.5 bar = 36 psi	Carry out test yourself or with a helper. Use a tyre gauge.
	Adjustment screws Screws and nuts are to be checked for tight fit.	Carry out test yourself or with a helper. Retighten the loosened adjustment screws. Contact specialist workshop upon demand.

WHEN	WHAT	REMARK
<p>Every 6-8 weeks (depending on distance covered)</p>	<p>Wheel attachments Wheel nuts or screws are to be checked for tight fit</p>	<p>Do it yourself or with the aid of a helper.</p> <p>Securely tighten any loosened wheel nuts or screws and retighten again after 10 operating hours or resp. 50 km.</p> <p>Contact specialist workshop upon demand.</p>
<p>Every 2 months (depending on distance covered)</p>	<p>Check tyre profile Minimum tread = 1 mm</p>	<p>Carry out a visual check yourself or with a helper.</p> <p>If the tyre profile is worn down or if the tyre is damaged, consult a specialist workshop for repairs.</p>
<p>Every 6 months (depending on frequency of use)</p>	<p>Check</p> <ul style="list-style-type: none"> - Cleanness. - General condition. 	<p>View < <i>Service</i> > in document < <i>Safety and general handling instructions electronic vehicles</i> >.</p> <p>Do it yourself or with the aid of a helper.</p>
<p>Manufacturer recommendation:</p> <p>Every 12 months (depending on frequency of use)</p>	<p>Maintenance jobs</p> <ul style="list-style-type: none"> - Vehicle - Battery charger 	<p>To be carried out by the specialist dealer.</p>

Fuses

Replacing the fuses

Before replacing fuses, park the electric wheelchair on a level surface and secure it from rolling away.

☞ Therefore observe chapter < *Securing the electric wheelchair* >.

Attention:

! Only replace the safety fuse with a safety fuse of the same type!

New fuses can be obtained for example at petrol stations.

Note:

If the safety fuse blows again, take the battery to a specialist dealer for repair.

Fuse

Mains-/battery fuse [1]

The flat fuse for the main / battery current is located in the fuse holder under the seat, on top of the batteries (2).

☞ Please observe the < *Technical data* >!

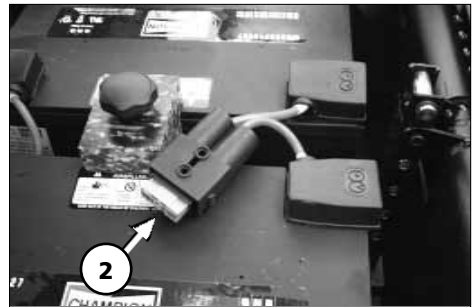
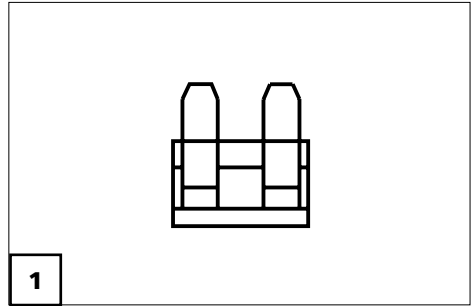

Tyre damage on pneumatic tyres

☞ For repairing tyre damage we recommend the use of a foam cartridge that is available in speciality shops. – Afterwards look up a specialist workshop as soon as possible.

Lighting

Note:

If a turn-signal bulb is defective, the remaining one blinks at double frequency.

-  When replacing always use bulbs with the same performance data.

Adjusting the headlights

Vertical alignment

The headlights should be set in such a way that the light cone is visible on the road. – The lower edge of the light cone should be set at distance of 3 meters to the front of the wheelchair.

Note:

The headlights might need to be readjusted after adjustment of the seat angle.

Press down the dispersion disc [1] at the upper or lower edge in order to adjust the headlights.



FAULT CORRECTION

Fault	Cause	Remedy
LED/LCD-display of the operating module is not lit after switching it on.	Main-/battery fuse is defective or not correctly inserted.	Replace defective fuse or clean contacts and insert correctly.
	Plug connection of the power supply without contact.	Check the plug connections.
Electric wheelchair does not move forward.	The selection lever drive-/push mode is set to push mode.	Move the selection lever for the drive/push mode into the drive mode position and make sure it clicks into place.
	Plugged connection on the drive misses contact.	Have the fault corrected by a specialist workshop.
	Batteries or power supply defective.	Have the fault corrected by a specialist workshop.
Error code display	Observe the operating manual < <i>operating module</i> >.	View < <i>error diagnostics</i> > in the operating manual for the operating module.
Lighting not active.	Filament bulb defective.	Replace defective filament bulb.
	Lighting fuse or drive electronics defective.	Let it be repaired or replaced by a specialist workshop.

TECHNICAL DATA

Kilometric performance

Kilometric performance depends to a large extent on the following factors:

- battery condition,
- weight of the driver,
- driving speed,
- driving style,
- road surface condition,
- driving conditions,
- ambient temperature.

The nominal values given by us are realistic under the following conditions:

- Ambient temperature of 27 °C.
- 100 % rated drive battery capacity as per the DIN standard.
- new condition of the drive batteries with more than 5 charging cycles.
- Nominal load of 75 kg.
- Without repeated acceleration.
- Level, firm driving surface.

The kilometric performance is greatly reduced by:

- frequent uphill driving,
- poor drive battery charge condition,
- low ambient temperature (e.g. in winter),
- frequent starting and stopping (e.g. in town traffic),
- aged, sulphated drive batteries,

- frequently necessary steering manoeuvres,
- reduced driving speed (especially at walking speed).

In practical use, the kilometric performance under 'normal conditions' is then reduced to approx. 80 % – 40 % of the nominal value.

Hill climbing ability

Gradients in excess of the permitted values (e.g. ramps) should for safety reasons only be driven when the wheelchair is empty!

TECHNICAL DATA

Model 2.322

All data within the following table relates to the standard version of the stated model.

Dimensional tolerance ± 1.5 cm, $\pm 2^\circ$.

Model: Electric wheelchair **model 2.322**

Type plate: rear right on the main frame

Class of use as per DIN EN 12184: B - Optimus 2 / C - Optimus 2 S

Life span: 5 years

Sound level: < 70 dB(A)

Protection class: IP X4

Electrical system:

Drive control: 24 Volt

Main fuse: 100 A

Lighting: 6 / 12 Volt

Dimensions with Ergoseat (Code 948 / 950 without head support):

Length incl. footplates: 1190 mm

General width: 680 mm

Height: 1100 mm

Seat depth (min. / max.): 45 / 49 cm

Seat depth (manufacturers setting): 49 cm

Seat width with code 43 (min. / max.): 38 / 50 cm

Seat width with code 43 (manufacturers setting): 43 cm

Seat width with code 48 (min. / max.): 48 / 56 cm

Seat width with code 48 (manufacturers setting): 48 cm

Seat height: 58 cm

Seat inclination (min. / max.): 5° / 20°

Seat inclination (manufacturers setting): 5°

Back support height: 54 cm

Arm support height from upper edge of seat (min. / max.): 17 / 27 cm

Transport dimensions with Ergoseat (without leg supports, without head support):

Length: 1030 mm

Width: 680 mm

Height (Back support folded forward onto the seat): 780 mm

Dimensions with seat Ergostar (Code 961 without head support):

Length incl. footplates: 1190 mm
General width: 680 mm
Height: 1170 mm

Seat depth: 50 cm
Seat width with code 24: 50 cm
Seat width with code 106 (min. / max.): 43 / 56 cm
Seat width with code 106 (manufacturers setting): 50 cm
Seat height: 59 cm
Seat inclination (min. / max.): 7° / 22°
Seat inclination (manufacturers setting): 7°

Back support height: 64 cm

Arm support height from upper edge of seat

with code 24 (min. / max.): 21 / 25 cm
with code 106 (min. / max.): 15 / 25 cm

Transport dimensions with seat Ergostar (without leg supports, without head support):

Length (back support toward the front): 1030 mm
Length (back support toward the back): 1340 mm
Width: 680 mm
Height (back support toward the front): 950 mm
Height (back support toward the back): 720 mm

Dimensions with seat Recaro:

Length incl. footplates: 1190 mm
General width: 680 mm
Height (min. / max.): 1300 / 1360 mm
Height (without head support): 1130 mm

Seat depth: 48 cm
Seat width (min./max.): 46 / 56 cm
Seat width (manufacturers setting): 46 cm
Seat height: 63 cm
Seat inclination (min. / max.): 20° / 35°
Seat inclination (manufacturers setting): 20°

Back support height (with head support) (min. / max.): 81 / 87 cm
Back support height: 64 cm

Arm support height from upper edge of seat (min. / max.): 18 / 28 cm

Transport dimensions with seat Recaro (without leg supports, without head support):

Length (back support toward the front):	1030 mm
Length (back support toward the back):	1260 mm
Width:	680 mm
Height (back support toward the front):.....	900 mm
Height (back support toward the back):	800 mm

Tyres:

Steering wheel (rear):.....	4.00 – 5 (12.5" = \varnothing 320 mm)
Drive wheel (front):	5.30/4.50 – 6 (14" = \varnothing 360 mm)

Tyre filling pressure:

Steering wheel:.....	2.5 bar (35 psi)
Drive wheel:	2.5 bar (35 psi)

Climatic data:

Ambient temperature:	-25 °C to +50 °C
Storage temperature with drive batteries:	-25 °C to +50 °C
Storage temperature without drive batteries:.....	-40 °C to +65° C

Drive batteries:

Drive batteries, sealed:.....	2 x 12 V 70 Ah (5 h) / 79 Ah (20 h)
Drive batteries, sealed:.....	2 x 12 V 80 Ah (5 h) / 97 Ah (20 h)
Drive batteries, sealed:.....	2 x 12 V 105 Ah (5 h) / 120 Ah (20 h)
Max. battery dimensions (LxWxH):	26 x 17.1 x 25.1 cm
or	32.9 x 17.1 x 23.7 cm
or	34.5 x 17.4 x 26.2 cm

Range (see Kilometric performance):

with drive batteries, sealed

79 Ah (20 h) with 6 km/h:.....	50 km
79 Ah (20 h) with 10 km/h:	45 km
97 Ah (20 h) with 6 km/h:.....	70 km
97 Ah (20 h) with 10 km/h:	60 km
97 Ah (20 h) with 15 km/h:	50 km
120 Ah (20 h) with 6 km/h:	85 km
120 Ah (20 h) with 10 km/h:	75 km
120 Ah (20 h) with 15 km/h:	60 km

Battery charger:

for batteries up to 65 Ah (20 h)24 V / 6 A
for batteries up to 85 Ah (20 h)24 V / 8 A
for batteries up to 125 Ah (20 h)24 V / 12 A
max. permitted charging current: 12 A

Performance - electric (view Kilometric performance):

Max. forward top speed: 6 km/h / 10 km/h / 15 km/h
Motor–continuous power rating (6 km/h / 10 km/h): 950 Watt at 3200 1/min
Motor–continuous power rating (15 km/h): 950 Watt at 4200 1/min
max. current of the power electronic (6 km/h / 10 km/h): 130 A
max. current of the power electronic (15 km/h): 180 A

Performance - mechanical (view Kilometric performance):

Max. obstacle height upwards: approx. 110 mm
(with 0.5m start-up distance)
Max. obstacle height downwards: approx. 130 mm
Ground clearance (drive unit / frame): 110 / 140 mm
min. turning radius: approx. 1200 mm
min. turning area: approx. 1400 mm
Max. permissible rising gradient: 10° (18 %)
Max. permissible falling gradient: 10° (18 %)
Max. permissible transverse gradient: 10° (18 %)
Static tilting safety in all directions: 15.5° (28 %)

Weights (basic equipment):

The values in the brackets () are valid for vehicles with 15 km/h:

Max. permissible total weight 6 km/h / 10 km/h / (15 km/h):..... 330 / (300) kg

Permitted axle load front:..... 210 / (190) kg

Permitted axle load rear: 140 / (130) kg

max. user weight (including additional load):

up to 10 km/h:..... 150 kg

up to 15 km/h:..... 120 kg

max. additional loading: 10 kg

Empty weight (with 79 Ah sealed drive batteries of 24 kg): approx. 120 kg

Empty weight (with 97 Ah sealed drive batteries of 32 kg): approx. 136 kg

Empty weight (with 120 Ah sealed drive batteries of 40 kg): approx. 152 kg







Empty weight without drive batteries:.....approx. 72 kg

☞ *All weight indications are valid for the basic equipment without electric adjustments*

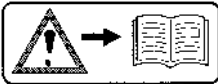
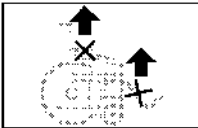
Weight of the heaviest single component:

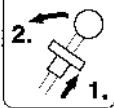
Electr. leg support (code 86):4.4 kg

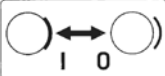
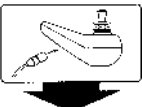
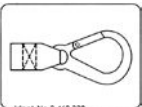
Meaning of the labels on the electric wheelchair

	<p>Attention! Read the operating manuals and other provided documentation.</p>
	<p>Do not lift the electric wheelchair at the arm supports or leg supports. Removable parts are not suitable for carrying.</p>
	<p>Drive mode</p>
	<p>Switching to push mode with the selection lever right.</p>
	<p>Push mode</p>
	<p>Push only on level surfaces.</p>
	<p>Drum Brake braked / released</p>
	<p>Indication for charging socket</p>
	<p>Attachment possibility of the transport safety.</p>
	<p>Indication for danger of jamming. – Do not reach in here</p>

Meaning of the symbols on the type plate



Manufacturer



Order number



Serial number



Production date (Year – Calendar week)



Permitted user weight



Max. permissible total weight

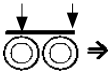

Permitted axle loads



Max. permissible rising gradient



Max. permissible falling gradient

max. ... km/h Max. permitted final speed



The product is approved as a seat within a motor vehicle



The product is **not** approved as a seat within a motor vehicle.

INSPECTION CERTIFICATE

Vehicle data:

Model:

Delivery note no.:

Serial-no.(SN):

Recommended safety inspection 1st year (at least every 12 months)

Stamp of specialist dealer:

Signature: _____

Place, date: _____

Next safety inspection in 12 months

Date: _____

Recommended safety inspection 2nd year (at least every 12 months)

Stamp of specialist dealer:

Signature: _____

Place, date: _____

Next safety inspection in 12 months

Date: _____

Recommended safety inspection 3rd year (at least every 12 months)

Stamp of specialist dealer:

Signature: _____

Place, date: _____

Next safety inspection in 12 months

Date: _____

Recommended safety inspection 4th year (at least every 12 months)

Stamp of specialist dealer:

Signature: _____

Place, date: _____

Next safety inspection in 12 months

Date: _____

Recommended safety inspection 5th year (at least every 12 months)

Stamp of specialist dealer:

Signature: _____

Place, date: _____

Next safety inspection in 12 months

Date: _____

NOTES

WARRANTY / GUARANTEE

We accept legal liability for this product within the scope of our general terms and conditions and warranty and the guarantee according to our described quality service. For warranty and guarantee demands please contact your specialist dealer with following Warranty/Guarantee section and the there included information on model description, delivery note number with delivery date and serial number (SN).

The serial number (SN) can be read off of the type plate.

Precondition for the acceptance of liability in any case is the intended use of the product, the use of original spare parts by specialist dealers as well as maintenance and inspections in regular intervals.

Guarantee is not granted for surface damages, tyres of the wheels, damages due to loosened screws or nuts as well as worn out attachment holes due to frequent assembly work.

Furthermore, damage to the drive and electronics caused by improper cleaning using steam cleaning equipment or the deliberate or accidental flooding of the components are also excluded.

Interferences through radiation sources such as mobile phones with high transmission power, HiFi-equipment and other extreme interference radiators outside of norm specifications cannot be declared as warranty or guarantee claims.

Attention:

- ! Failure to observe the instructions
- in the operating manual, improperly carried out maintenance work and, especially, technical changes and additions (add-ons) carried out without our prior consent will lead to a general loss of guarantee and product liability.

Note:

This operating manual as a part of the product is to be handed out in case of a change of user or owner.

We reserve the right to make technical improvements.



The product conforms with the EC Directive 93/42/EEC (MDD) for medical products.

Warranty / Guarantee section

Please fill out! Copy if necessary and send the copy to the specialist dealer.

Warranty / Guarantee

Model designation:

Delivery note no.:

SN (view type plate)

Date of delivery:

Stamp of the specialist dealer:

Inspection certificate for transfer

Vehicle data:

Serial-no.(SN):

Model:

Delivery note no.:

Stamp of specialist dealer:

Signature: _____

Place, date: _____

Next safety inspection in 12 months

Date: _____



┌ Your specialist dealer: ┐

└

└

MEYRA[®]
ORTOPEDIA
We move people.

MEYRA-ORTOPEDIA
Vertriebsgesellschaft mbH
Meyra-Ring 2 · D-32689 Kalletal-Kalldorf
P.O. Box 1 703 · D-32591 Vlotho
Fon +49 (0)5733 922-311
Fax +49 (0)5733 922-9311
info@meyra-ortopedia.de
www.meyra-ortopedia.de

205 340 001 • (Status: 2011-03) Original operating manual! Subject to technical modifications!