



CE

GB

OPERATING MANUAL ELECTRIC WHEELCHAIR

Model 1.610

Model 1.611

Model 1.612

MEYRA[®]
ORTOPEDIA
We move people.

Contents

Introduction	6
Indications	7
Specifications	7
List of models	7
Acceptance	7
Use	8
Adjustment	8
Life span	9
Overview	10
Model: 1.610	10
Model: 1.611	11
Model: 1.612	12
Handling the electric wheelchair	13
Securing the electric wheelchair	13
Functional checks	13
Driving behaviour.....	13
Brakes	13
Operating brake	13
Braking the wheelchair	13
Parking brake	13
Locking the brakes.....	14
Releasing the brakes.....	14
Drive-/push mode	15
Selecting the push mode.....	15
Selecting the motor mode	15

Selecting the operation	16
Pre-operation checks.....	18
Battery charging procedure.....	18
Positioning the operating module.....	19
Function description.....	19
Adjusting the distance to the padded arm support.....	19
Removing the operating module.....	19
Inserting the operating module.....	19
Swivelling the operating module.....	20
Height adjustment of the operating module.....	20
Leg supports	21
Calf belt.....	21
Removing the calf belt.....	21
Attaching the calf belt.....	21
Length adjustment of the calf belt.....	21
Leg support lower part.....	22
Footplates.....	22
Footboard.....	22
Leg support upper part.....	23
Turning the leg supports to the side.....	23
Swivelling in the leg supports.....	24
Removing the leg supports.....	25
Attaching the leg supports.....	25
Mechanically height-adjustable leg supports.....	26
Lifting/lowering the leg support.....	26
Electrically height-adjustable leg support.....	27
Height adjustment.....	27
Removing the electrically height adjustable leg support.....	28
Hanging the electrically height adjustable leg support into place.....	29

Arm supports	30
Removing the arm support	30
Inserting the arm support.....	30
Back support	31
Folding down the back support.....	31
Unfolding the back support.....	31
Adjusting the back support angle	31
Secure positions of the back support	32
Adjustable back	33
Removing the back support upholstery	33
Placing the back support upholstery	33
Electrically adjustable back support	34
Folding down the electrically adjustable back support.....	34
Unfolding the back support.....	34
Back support upholstery.....	35
Secure positions of the back support	35
Seat	36
Seat pad	36
Seat cushion.....	36
Seat inclination.....	36
Electrically adjusting the seat angle	37
Seat height adjustment	38
Retaining strap	39
Head support	40
Adjustment of the head support.....	40
Attendant control with priority switch	41
Positioning the controller.....	41
Lighting	42
Rear-view mirror	42
Removing the rear-view mirror	42
Attaching the rear-view mirror.....	42
Adjusting the rear-view mirror	42

Loading and transportation	43
Loading	43
Transport of people inside a motor vehicle	43
Transport security	44
Maintenance	44
Maintenance	44
Maintenance schedule.....	45
Fuses	47
Replacing the fuses	47
Lighting	48
Headlights.....	48
Fault correction	49
Technical data	50
Kilometric performance	50
Hill climbing ability	50
Model 1.610 / 1.611	51
Model 1.612	56
Meaning of the labels on the electric wheelchair	60
Meaning of the symbols on the type plate	61
Inspection certificate	62
Notes.....	63
Warranty / Guarantee.....	66
Warrantee / Guarantee section	67
Inspection certificate for transfer	67

INTRODUCTION

We thank you for the confidence you have placed in our company by choosing an electric wheelchair from this series.

With all equipment and their accessories the electric wheelchair offers the respective adaptation to your disability.

Like any other vehicle, an electric wheelchair is a technical aid. It is subject to explanations, requires regular care and can cause danger when used improperly. The correct handling must therefore be learned. This operating manual is to help you get accustomed to the handling of the electric wheelchair as well as to prevent accidents.

Note:

Please note that the illustrated equipment variants can deviate from your model.

We have therefore also listed chapters with options that might not be applicable for your vehicle.

Attention:

 Read and observe the following

- documentation belonging to the electric wheelchair before first use:
- this operating manual,
- the operating manual < *Operating module* > ,
- the safety and general handling instructions < *Electric vehicles* > .

Note:

Children and juveniles should read the documentation belonging to the electric wheelchair together with their parents respectively a

supervisor or accompanying person before first use.

Users with visual impairments can find the PDF-files of above mentioned documents on our website under:

< www.meyra-ortopedia.com > .

Alternatively users with visual impairments can have the documentation read out by a helper.

Additional information about our products can be found on our website:

< www.meyra-ortopedia.com > .

 Contact your specialist dealer when required.

INDICATIONS

If the following indications occur we recommend the application of this mobility product:

- ☞ Walking disability resp. extremely limited walking ability as part of the basic need to move around in your own home.
- ☞ The need to be able to leave home for a short walk in fresh air or in order to reach the places, commonly in the perimeter of the home, required to fulfil basic needs.

SPECIFICATIONS

The electric wheelchair is an environment-friendly electric vehicle. It was developed to extend the mobility of persons with health-related or age-related restrictions.

- ☞ The model has been assigned the 'Use Class B' as per the EN12184 standard.

LIST OF MODELS

This operating manual applies to the following models:

- Model 1.610
- Model 1.611
- Model 1.612

ACCEPTANCE

All products are checked for faults in the factory and packed in special boxes.

☞ **Note:**

However, we request that you check the vehicle for possible transport damage immediately on receipt – preferably in the presence of the carrier.

☞ **Note:**

The packaging of the wheelchair should be stored for a further transport that might become necessary.

USE

The electric wheelchair, with attached leg supports and arm supports, serves exclusively for the conveyance of one sitting person. Other pulling or transporting uses do not comply with its intended purpose.

This model is an electric wheelchair especially for indoor and outdoor use on firm, level surfaces.

The electric wheelchair offers manifold adjustment possibilities to individual vital statistics.

The wheelchair should be adapted to your needs by a specialist dealer before the first use. The adaptation will take into account the driving experience, the physical limits of the user and the main place of use of the wheelchair.

Attention:

- ! Always have adaptation and adjustment work carried out by a specialist dealer.

ADJUSTMENT

The specialist workshop will hand out the electric wheelchair to you under consideration of all relevant safety instructions, ready for operation and adjusted to your needs.

Note:

- ☞ We recommend a regular control if the wheelchair adjustment in order to ensure a long-term optimal provision even with changing illness/handicap patterns of the user. Especially for children and juveniles an adjustment every 6 months is recommendable.
- ☞ We recommend regular medical exams in order to ensure safety for active participation in traffic.
- ☞ Retrospective adjustments should be carried out solely by the specialist dealer!

LIFE SPAN

We expect an average lifespan of about 5 years for this product, as far as the product is applied for its designated purpose and all maintenance and service guidelines.

The life span of your product depends upon the frequency of use, the application environment and care.

The implementation of spare parts can prolong the life span of the product. As a rule spare parts are available up to 5 years after production is discontinued.

☞ The indicated lifespan does not constitute additional guarantee.

OVERVIEW

Model: 1.610

The overview shows the most important components and operating devices of the electric wheelchair.

Pos. Description

- 1 Back support
- 2 Arm support
- 3 Seat cushion
- 4 Leg support
- 5 Calf belt
- 6 Footplate
- 7 Steering wheel
- 8 Drive wheel
- 9 Push bar
- 10 Operating module
- 11 Front lighting
- 12 Selection lever drive-/push mode
- 13 Support castor
- 14 Battery box
- 15 Rear lighting

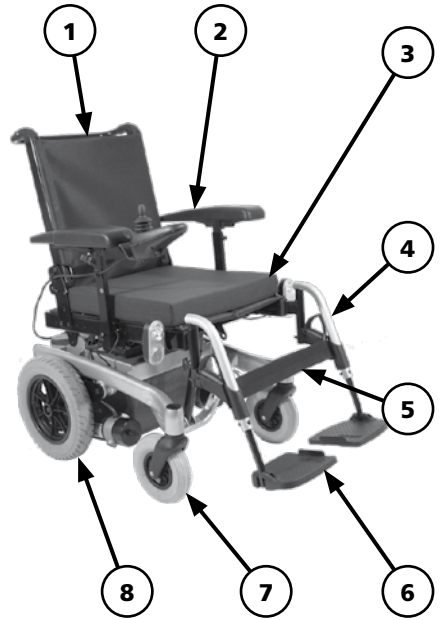

Model: 1.611

The overview shows the most important components and operating devices of the electric wheelchair.

Pos. Description

- 1 Back support
- 2 Arm support
- 3 Seat cushion
- 4 Leg support
- 5 Calf belt
- 6 Footplate
- 7 Steering wheel
- 8 Drive wheel
- 9 Push bar
- 10 Operating module
- 11 Front lighting
- 12 Selection lever drive-/push mode
- 13 Support castor
- 14 Battery box
- 15 Rear lighting
- 16 Baggage rack

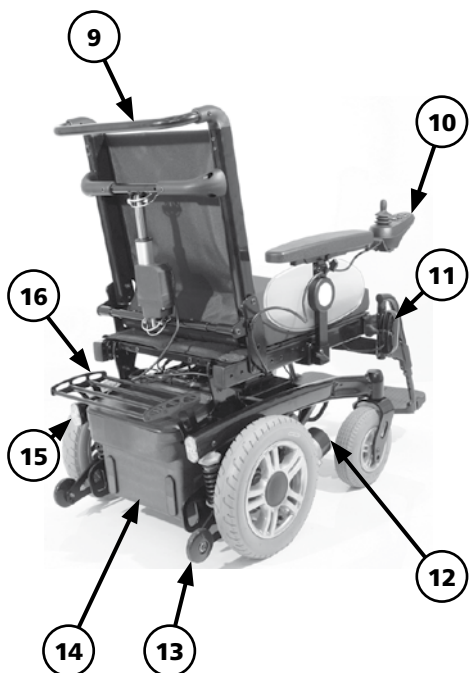
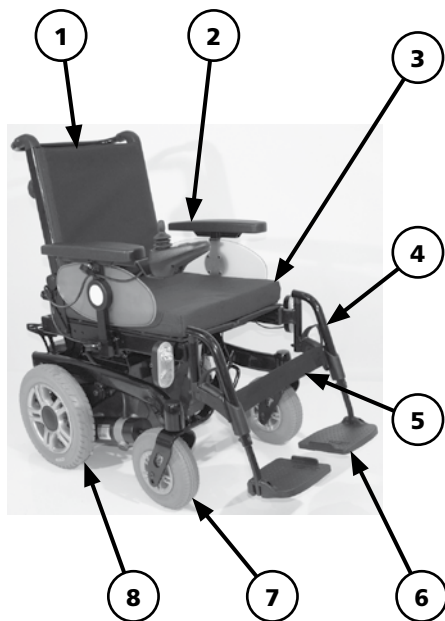

Model: 1.612

The overview shows the most important components and operating devices of the electric wheelchair.

Pos. Description

- 1 Back support
- 2 Arm support
- 3 Seat cushion
- 4 Leg support
- 5 Calf plate
- 6 Footplate
- 7 Steering wheel
- 8 Drive wheel
- 9 Push bar
- 10 Operating module
- 11 Front lighting
- 12 Selection lever drive-/push mode
- 13 Support castor
- 14 Battery box
- 15 Rear lighting
- 16 Baggage rack



HANDLING THE ELECTRIC WHEELCHAIR

Securing the electric wheelchair

The electric wheelchair is to be secured as follows to prevent it from rolling off unintentionally:

1. Switch the selection lever for drive-/push mode up to drive mode on both sides.
2. Switch the operating module off.

Functional checks

The functions and safety of the electric wheelchair must be checked before the start of each journey.

☞ For this observe chapter < *Inspections before starting to drive* > in the accompanying documentation.

Driving behaviour

You define the speed and direction yourself with the joystick movements (driving and steering lever) while driving as well as the preadjusted maximum final speed of your electric wheelchair.

BRAKES

Operating brake

The motors work electrically as operating brake and carefully brake the electric wheelchair down without jerks to stillstand.

Braking the wheelchair

For allotted braking of the wheelchair slowly guide the joystick (steering and driving lever) back to the centre position (zero-setting).

☞ The electric wheelchair stops in shortest distance after releasing the joysticks.

Parking brake

The parking brakes are only effective when the selection lever drive-/push mode is set to drive mode on both drives. They disengage automatically when the wheelchair starts off.

The parking brakes are manually disengaged by switching the selection lever drive-/push mode on both drives to push mode.

Locking the brakes

To engage the brakes swivel the selection lever drive-/push mode on both sides as far as possible into drive mode [1].

- ☞ Activation of the selection lever is intended for an accompanying person.

Attention:

- ! It should not be possible to push
- the electric wheelchair forward when the brakes are engaged.

Releasing the brakes

To loosen the brakes swivel the selection lever drive-/push mode on both sides down as far as possible into push mode [2].

- ☞ Activation of the selection lever is intended for an accompanying person.

Attention:

- ! Only transfer into or out of the
- electric wheelchair when the electric wheelchair is switched off and the selection lever drive-/push mode on both sides is in drive mode!
- An unintentional movement of the joysticks (driving and steering lever) can otherwise lead to an uncontrolled start of the electric wheelchair! – Danger of accident!



Drive-/push mode

Attention:

- ! Only switch the electric wheelchair to push mode when it is standing still for positioning or in case of emergencies, but not on slopes/hills.
- ☞ The electric magnetic brakes are switched off in the push mode.
 - A braking of the electric wheelchair is then only possible by switching to the drive mode.
- ☞ Grab hold of the push handle and back support in order to shunt the electric wheelchair.

Selecting the push mode

1. Switch off the operating module because the pushing will otherwise be made difficult by the electric system.
 - ☞ Observe the operating manual < *Operating module* >.
2. Disengage the brakes [1].
 - ☞ Therefore observe chapter < *Releasing the brakes* >.
- ☞ The electric wheelchair can now be pushed.

Selecting the motor mode

1. Activate the brakes [2].
 - ☞ Therefore observe chapter < *Locking the brakes* >.
2. Switch the operating module on.
 - ☞ Observe the operating manual < *Operating module* >.
- ☞ The electric wheelchair is now ready for use again.



SELECTING THE OPERATION

In order to obtain operational readiness of the electric wheelchair the following directions are to be carried out in the indicated order.

Note:

Charge the drive batteries via the operating module before the first journey.

1. Establish drive mode

Switch the drive motors to the drive mode [1]. – For this engage the brakes.

Observe chapter < *Releasing the brakes* >.

2. Check the correct fit of the battery/mains fuse

Blade-type fuse:

The blade fuse for the battery/main current has to sit tightly in the fuse holder (2).

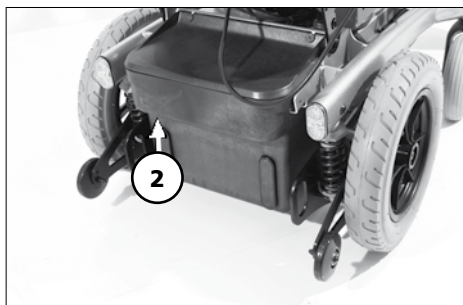

3. Check the position of the operating module

The operating module should be positioned in such a way that you can comfortably and safely steer the electric wheelchair.

Adjusting the distance to the padded arm support:

The distance of the operating module to the padded arm supports can be adjusted after loosening the clamping screw (3).

Attention:

! After the adjustment retighten the clamping screw.

☞ Therefore observe chapter < *Positioning the operating module* >.

Height adjustment

☞ Therefore observe chapter < *Positioning the operating module* >.

4. Switch the operating module on

Press the ON/OFF-key (4) on the control panel of the operating module.

☞ Observe the operating manual < *Operating module* >.

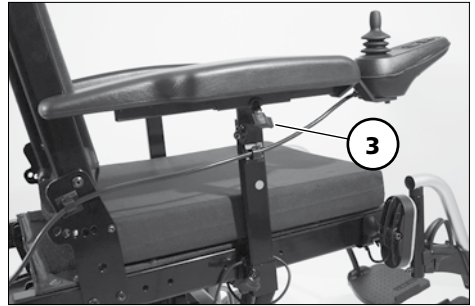

Pre-operation checks

Before starting to drive, the following should be checked:

- ☞ the battery charging condition,
 - ☞ the setting of the preselected final speed.
- For this observe the operating manual < *Operating module* >.

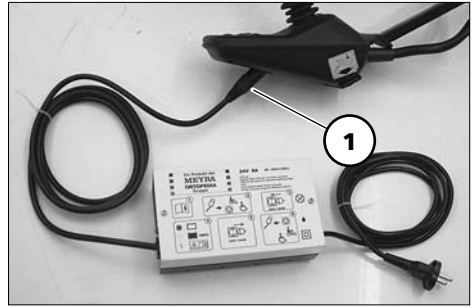

Battery charging procedure

- ☞ For the battery charging procedure also observe the operating manual of the battery charger.
1. Lock the electric wheelchair.
 - ☞ Therefore observe chapter < *Securing the electric wheelchair* >.
 2. Insert the battery charger plug into the operating module (1).

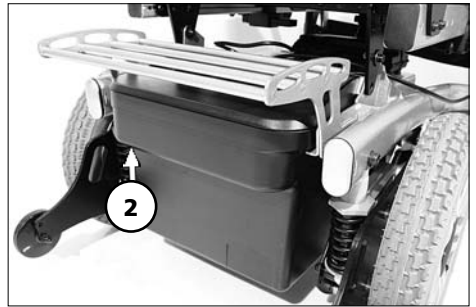

Attention:

- ! Do not insert any objects other
 - than the battery charger plug into the battery charging socket.
 - Danger of short circuit!
3. Switch the battery charger on, resp. insert the main plug of the battery charger into the corresponding power socket.
 - The battery charging procedure is initiated.
 - ☞ The charging procedure only runs with an intact mains/battery fuse (2)!
 4. After a completed charging procedure disconnect the battery charger from the socket and remove the battery charging plug from the battery charging socket.

Positioning the operating module

Function description

You will find a detailed description of the keys and symbols in the operating manual for < *Operating module* >.

The position of the operating module can be adjusted to suit the individual size of the user. The operating module can also be removed for transportation or storage and can be laid on the seat or stored separately.

Attention:

- ! Switch off the operating module
- before adjusting/removing it.

Adjusting the distance to the padded arm support

Slacken the clamping screw distance adjustment (1). Afterwards slide the operating module into the desired position. In doing so carefully guide the cable and retighten the clamping screw (1) securely.

Removing the operating module

In order to remove the operating module loosen the clamping screw (1) and disconnect the plugged connection (2) (4).

- ☞ Do not pull on the cable while doing so.

Afterwards pull out the operating module toward the front out of the arm support tube.

Inserting the operating module

For drive mode insert the operating module from the front into the arm

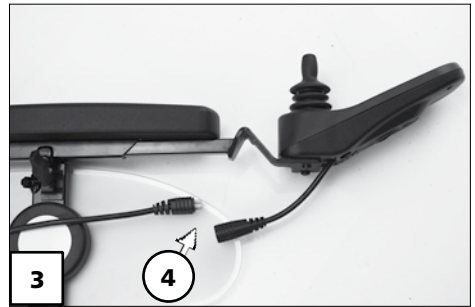
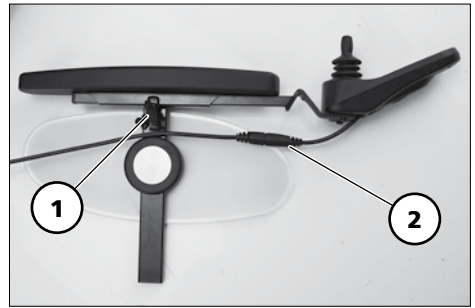

support tube [3] and adjust the distance to the padded arm support.

- ☞ Therefore observe chapter < *Adjusting the distance to the padded arm support* >.

Afterwards re-establish the plugged connection (4) (2).

- ☞ Check the function of the operating module.

Swivelling the operating module

With the optional swivel away operating module adapter [1] the operating module can be swivelled back to the side (2) so that it is located parallel to the arm support. This makes it possible, for example:

- to drive closer to a table,
- remove the operating module more easily.

For regular drive mode the operating module can be swivelled back toward the front until it engages back into the magnetic lock [1].

Note:

 The power of the magnets (3) can be reduced, for example with tape on top of the magnets, for easier swivelling of the operating module.

 Should the operating module be positioned too close to the arm support, move it forward before swivelling.

Attention:

-  Do not grab into the area of the cross brace. – Danger of jamming!

Height adjustment of the operating module

Loosen the clamping screw (4) to adjust the height of the operating module.

Attention:

-  After the adjustment retighten the clamping screw.

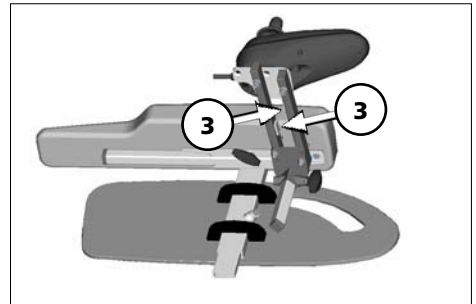
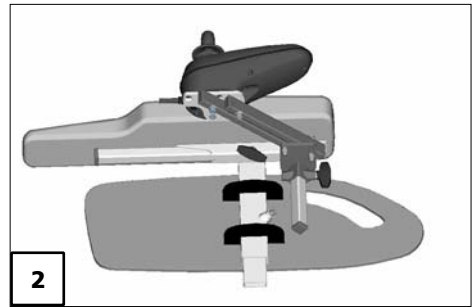
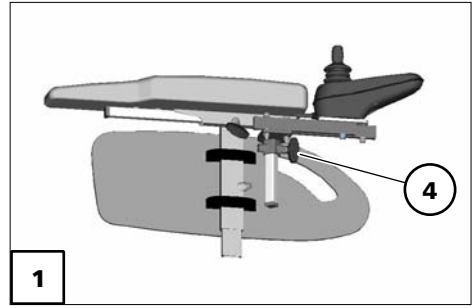

LEG SUPPORTS

Attention:

- ! Before any actions on the leg supports the wheelchair is to be secured against unintentional rolling motions.

☞ Therefore observe chapter < *Securing the electric wheelchair* >.



Calf belt

The removable calf belt (1) prevents the feet from sliding off the back of the footplates.

Attention:

- ! Do not drive without the calf belt.
- – Danger of accident!

Note:

The calf belt must be removed in order to swivel away the leg supports [2].

- ☞ The calf belt is omitted for height adjustable leg supports and is replaced by a calf pad.



Removing the calf belt

For removal the calf belt is to be pulled from the attachment pins (3).

Attaching the calf belt

For attachment both loops of the calf belt are slid over the attachment pins [4].

Length adjustment of the calf belt

For length adjustment, the calf belt is guided around the special attachment pins (2) and adjusted in length with a velcro fastener.

Leg support lower part

The footplates, resp. footboard needs to be folded up before entry or exit [1].

- ☞ Check the locking points!
 - Remove both feet from the footplates.
 - Remove the calf belt (2), if present.
 - ☞ Hereto observe chapter < Calf belt >.

☞ Note:

Before starting to drive the footplates resp. footboard need to be folded back down [3] and the calf belt attached.

Footplates

The footplates can be folded outward and up [1] resp. inward and down [3].

Footboard

Fold the footboard up before swivelling away and removing the upper leg support.

Folding up the footboard

In order to fold up the footboard lift the loose end of the footboard (4) as far as possible.

Folding the footboard down

In order to fold down the footboard, lower the loose end of the footboard as far as possible down onto the footboard bracket [5].

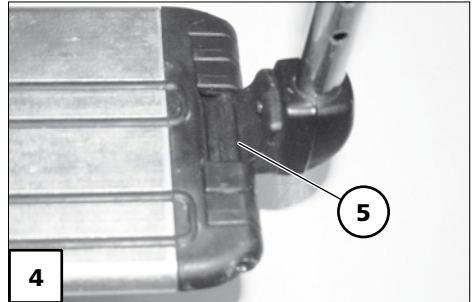
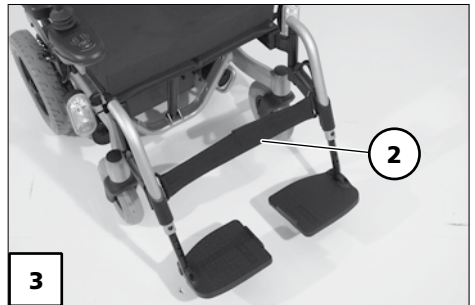

Leg support upper part

The upper leg support with an inserted lower leg support is termed leg support.

Turning the leg supports to the side



For easy transfer out of/into the electric wheelchair as well as driving closer to a closet, bed or bathtub the leg supports can be swivelled away toward the in-/outside [1] and [2].

Note:

Remove the calf belt before swivelling away the leg supports.

 Hereto observe chapter < *Calf belt* >.

Attention:

-  Leg supports turned to the side are released automatically and can easily come off. Note this when handling (e.g. transport).
- Fold up the footplates resp. footboard in order to swivel away the leg supports.
 -  Hereto observe chapter < *Leg support lower part* >.
- Afterwards pull or press the respective locking lever (3) backward and swivel the corresponding leg support outward.

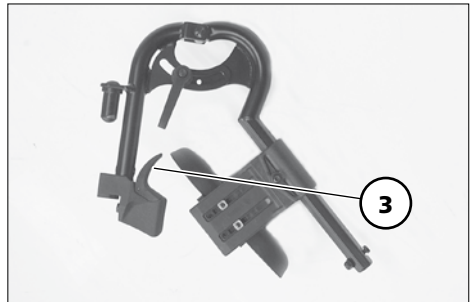

Swivelling in the leg supports

For inward swivelling, let the leg supports swivel forward until the lock audibly engages [1].

Note:

After audibly swivelling the leg supports inward check the respective locking device.

 Afterwards observe chapter < *Lower leg support* >.



Removing the leg supports

For easy transfer into and out of the electric wheelchair as well as a reduced wheelchair length (important for transport) the leg supports can be removed [1].

👉 **Note:**

Remove the calf belt before swivelling away the leg supports.

👉 Hereto observe chapter < *Calf belt* >.

- For removal first swivel the leg support sideways and then remove them toward the top [1].

👉 Therefore observe chapter < *Swivelling away leg supports* >.

- 👉 Watch for possible danger of jamming!



Attaching the leg supports

- For inserting press the leg supports, swivelled to the side, parallel to the front frame tube and lower it into place [2]. – In doing so the holding pin must slide into the frame tube.

👉 **Note:**

After attachment swivel the leg supports inward [3].

👉 Therefore observe chapter < *Swivelling in the leg supports* >.



Mechanically height-adjustable leg supports

Attention:

- ! Never put the free hand into the adjustment mechanism while adjusting the height adjustable leg support. – Danger of crushing!
- Have the leg support that is to be adjusted secured against falling away by an accompanying person.

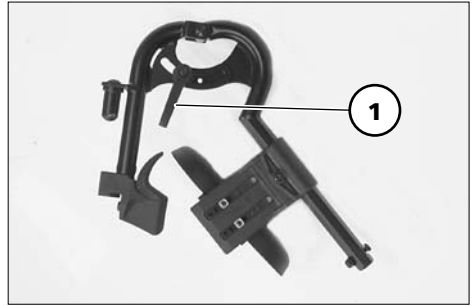

Lifting/lowering the leg support

1. Before lifting/lowering relieve the leg support by an accompanying person by slightly lifting it up.
2. Afterwards loosen the clamping lever (1) and have the leg support lifted/lowered slowly to the desired level by an accompanying person.

Attention:

- ! Do not let the leg support drop on its own weight. – Danger of injury!
3. After the adjustment retighten the clamping lever (1) securely.

Electrically height-adjustable leg support

The electrically height adjustable leg support [1]+[2] automatically receives electric contact when hooked on.

Attention:

- ! Never put the free hand into the adjustment mechanism while adjusting the height adjustable leg support. – Danger of crushing!

Height adjustment

–For height adjustment, raise or lower the leg support to the desired height via the operating module (1)+(2).

- 👉 Observe the operating manual < *Operating module* >.

Attention:

- ! Observe the safety and general handling instructions < *Electric vehicles* >!



Removing the electrically height adjustable leg support

In order to remove the leg support, depending on version, first pull the locking lever (1) back, press it in or fold it up or down.

Afterwards swivel the leg support sideways and remove it toward the top [2].

☞ Therefore observe chapter < *Swivelling away leg supports* >.

Attention:

- ! When the electrically height adjustable leg supports are removed the electric contact (3) needs to be protected from dampness, water and dust or dirt (e. g. for longer storage)!

– Possible function error of the electrical adjustment.

☞ For protection you can for example use the optional cover cap.

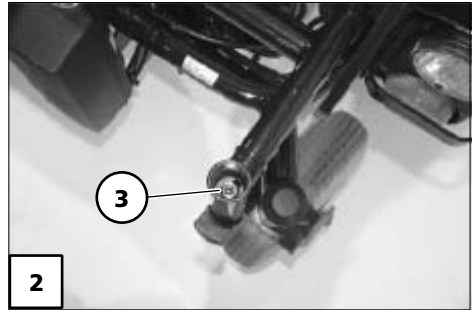
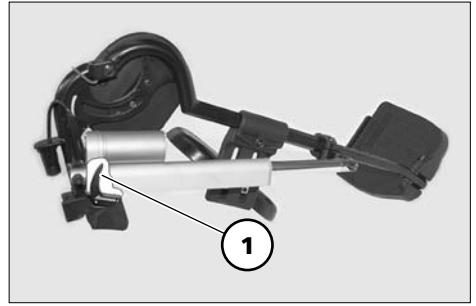

Hanging the electrically height adjustable leg support into place

👉 **Note:**

After attachment swivel the leg supports inward.

👉 Therefore observe chapter < *Swivelling in the leg supports* >.

- Press the leg supports, swivelled to the side, parallel to the front frame tube and lower it into place.
 - In doing so the holding pin must slide into the frame tube (1).

👉 Conduct a function test on the electrically height adjustable leg support!

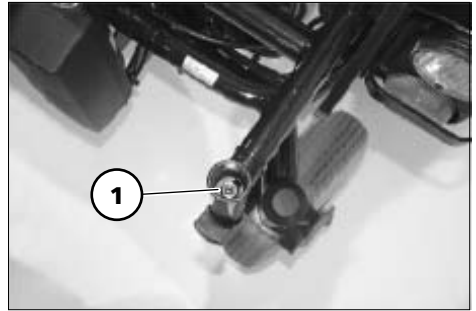

ARM SUPPORTS

Attention:

- ⚠ Do not use the arm supports [1] to lift or carry the electric wheelchair.
- Do not drive without the arm supports!

Removing the arm support

To remove the arm support, loosen the clamping screw (2) first and then pull out the arm support toward the top .

👉 Note:

The operating module (4) must be removed first if the arm support on the control side is to be removed.

- 👉 Therefore observe chapter < Removing the operating module >.

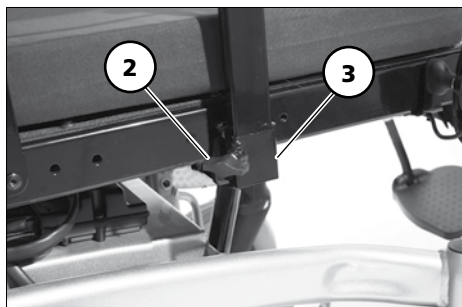

Inserting the arm support

For inserting the arm support, first slide the arm support as far as possible into the bracket (3) and then tighten the clamping screw (2).

👉 Note:

To insert the operating module (4) observe chapter < Inserting the operating module >.



BACK SUPPORT

The back support can be folded down for storage or transport.

Note:

For better demonstration of the wire cable (1) the back support is shown without cushion.

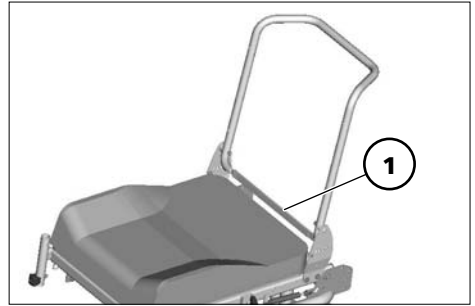



Folding down the back support

- If required remove the seat pad (velcro fastener).
- Disengage the back support by pulling or pressing the wire cable (1) at its centre and fold it onto the seat [2].

Unfolding the back support

- For this raise the back support and pull the pressure bolts inward by pulling or pressing on the wire cable (1).
- Release the wire cable in order to lock the back support in the desired position (3). – Slide the back support until the pressure bolts audibly click into place.
- If required replace the seat pad.

Note:

-  The greasing of the thrust bolts is recommended for an easier latching of the back support.
-  Check the lock of the back support.

Adjusting the back support angle

- Unlock the back support by pulling or pressing the centre of the wire cable (1).
- Release the wire cable in order to lock the back support in the de-

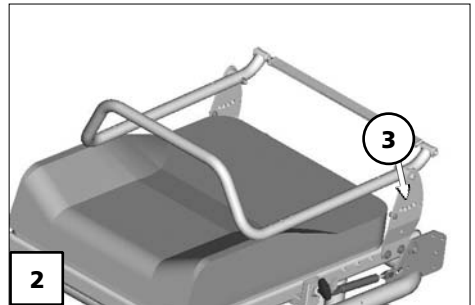

sired position (3). – Slide the back support until the pressure bolts audibly click into place.

-  Check the lock of the back support.

Secure positions of the back support

The diverse possible seat adjustments also includes such settings, that may only be used as resting positions, since they might lead to instable driving conditions in drive mode.

Depending on the set seat inclination you may only select certain back support adjustments for driving on hills [1].

Note:

For your safety you should have the set seat inclination confirmed by your specialist dealer and marked in the chart!

Attention:

- Any change to the seat inclination will lead to different safe back support adjustments!

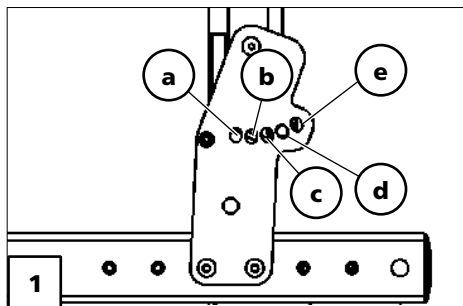

Example:

Adjusted seat angle:..... 6°

The pressure bolt of the back support may only be in positions c, d, or e when driving on hills/slopes.

Model 1.610/1.611

Seat inclination	Adjusted seat inclination	safe position of the back support inclination [1]
0°		c, d
2°		c, d
4°	manufacturer setting	c, d
6°		c, d, e
8°		d, e
10°		d, e

Model 1.612

Seat inclination	Adjusted seat inclination	safe position of the back support inclination [1]
0°		c, d
4°	manufacturer setting	c, d
8°		c, d, e
12°		c, d, e

Adjustable back

The adjustable back is adjustable through a velcro strap on the spanning straps (2).

Removing the back support upholstery

For removal, first pull off the rear part of the back support upholstery (1), then fold it over to the front and pull it off of the adjustable back strap (3).

Placing the back support upholstery

For placing the back support upholstery (1), lay it centred around the upper velcro straps (2) and attach it to the adjustable back strap with the velcro fasteners (3).

☞ For a soft upper edge you should leave a little space between the upper spanning belt (2) and the folded back support upholstery (1).

☞ **Note:**

When the user leans against the back support upholstery (1) again, pay attention that:

- ☞ The pressure of the back must be spread evenly throughout the back support upholstery.
- ☞ A complete hand should fit in between the cushion and back at the upper edge of the back support upholstery.
- ☞ The head of the user must be held in balance through the adjustment of the spanning straps.

The extended parts of the back support are fastened to the top or bot-

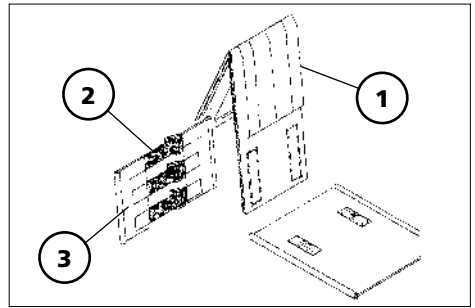

tom seat surface depending on the adjusted back support height (4).



Electrically adjustable back support

The back support [1] is electrically adjustable.

Note:

Herefore view the operating manual < *Operating module* >.

Attention:

-  Only adjust the back support when
-  the electric wheelchair is standing on a level surface. A danger of tipping over exists on gradients!

Folding down the electrically adjustable back support

Fold open the safety latch (3) first for folding over the electrically adjustable back support [2], then remove the pin (4).

-  Keep the back support and motor in position with one hand at the push bar.

Afterwards place the motor onto the lower rack and fold the back support forward [2].

Reinsert the pin (4) in order to prevent loss.

Unfolding the back support

After raising the back support [1] remove the pin (4), lift the motor and hang it into place. The reinsert the pin (4) and fold the safety bracket close [5].

-  Check the locking device after raising the back support up and reinserting the pin.

-  Keep the pin clean at all times for flawless function.

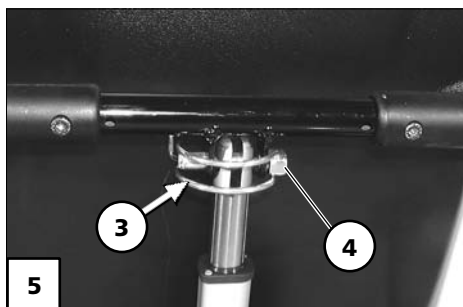

Back support upholstery

The back support upholstery is secured to the back support shell with Velcro fasteners and can be pulled off [1].

Secure positions of the back support

The diverse possible seat adjustments also includes such settings, that may only be used as resting positions, since they might lead to instable driving conditions in drive mode.

The electric wheelchair is equipped with a tilting switch, that limits the back support angle in combination with the seat angle.

Note:

The maximum back support adjustment is only possible with a seat angle of 0°.

 If the safe angle, even while driving, is exceeded the wheelchair automatically brakes to a stop and a < peep > will sound at every movement of the joystick. Continuing to drive is only possible when the back support, resp. seat angle is reduced.

Attention:

-  Any change to the seat inclination
- will lead to different safe maximum back support adjustments!

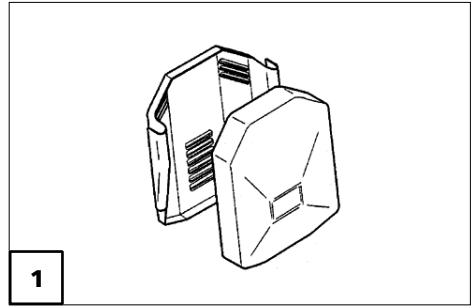

SEAT

Seat pad

The seat pad [1] is attached to the seat plate with velcro straps and can be removed for cleaning and maintenance.

Replace and attach the seat pad again after cleaning or maintenance [1]. – Velcro fastener.



Seat cushion

The seat cushion is placed with the burling side onto the seat plate [2].

Seat inclination

Attention:

- ⚠ Only adjust the seat angle [3] when the electric wheelchair is standing on a horizontal, level surface. A danger of tipping over exists on gradients!
- The seat-angle adjustment is not linked with an automatic speed reduction function.
- An increased danger of tipping over exists with a reclined back support.
- Before driving make sure that you have not adjusted a negative seat inclination, resp. that the seat inclination ensures a safe sitting position even while driving on hills/slopes.

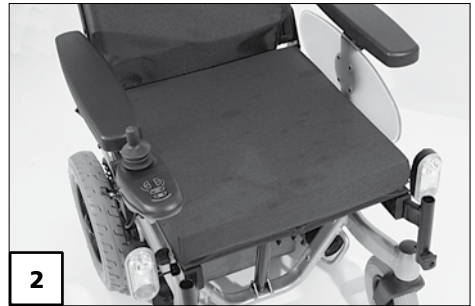

Electrically adjusting the seat angle

The seat inclination [1] is administrated through the operating module or a separate adjustment module.

🔧 **Note:**

Therefore observe operating manual < *Operating module* >.



Rising aid

The seat is angled forward for the stand-up aid [2] (negative seat angle).

🔧 The negative seat angle setting serves as support for getting up when the vehicle is standing.

🔧 When tilting the seat surface forward (rising aid) the steering wheels must face toward the back or one side, because otherwise the footplates will hit against the steering wheels.

🔧 Adjustment of a negative seat inclination may lead to contact of the lower leg supports with the ground and to a lifting on the steering wheels.

Attention:

! Before using the rising aid, secure the electric wheelchair and fold up the footplates.

🔧 Therefore observe chapter < *Securing the electric wheelchair* >.



Seat height adjustment

The seat height [1] can be adjusted through the operating module.

☞ This continuously increases the seat height by up to 300 mm.

☞ **Note:**

Therefore observe operating manual < *Operating module* >.

☞ If the seat is moved upward by more than 20 mm from the basic position, the speed is limited to km/h and the acceleration damped.

Negative activation:

With negative activation through the operating module the seat returns to the basic position.

☞ The limitation to speed and acceleration are cancelled.



RETAINING STRAP

The retaining strap serves to strap in a person sitting in the electric wheelchair.

- Additional stabilisation of the sitting position.
- Prevents the user from sliding forwards out of the electric wheelchair.
- Continuous adjustment to suit the user's needs.

Attention:

- ! Make sure that no objects are trapped between belt and the body! – Thus you avoid painful pressure points.

The retaining strap is screwed on, from the outer side, at the respective back support holder (1).

Note:

The retrospective assembly of a retaining strap is only to be carried out by a specialist workshop!

Attention:

- ! The retaining strap is not part of the retaining system for the electric wheelchair and/or the driver during transport in motor vehicles.

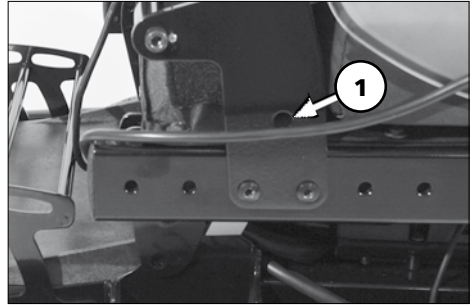

HEAD SUPPORT

The head support is swivel/proof, height- and depth adjustable and removable.

Attention:

- ! We recommend the fitting of two
- rear-view mirrors for driving with a head support.

Adjustment of the head support

The head support can be detached or adjusted in height after the clamping lever (1) has been slackened.

Attention:

- ! The maximum height adjustment
- is indicated by the marking!

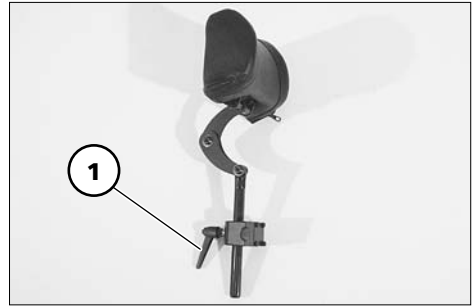

ATTENDANT CONTROL WITH PRIORITY SWITCH

The control unit for accompanying person enables the accompanying person an easy control of the electric wheelchair with auxiliary operating module.

Positioning the controller

Note:

Switch off the operating module before position adjustment! – This prevents an unwanted movement of the electric wheelchair.

Height adjustment

Hold the operating module and then slacken the clamping screw (1).

Move the operating module into the desired position and retighten the clamping screw.

Angle adjustment

Hold the operating module and then slacken the clamping screw (2).

Swivel the operating module into the desired position and retighten the clamping screw.

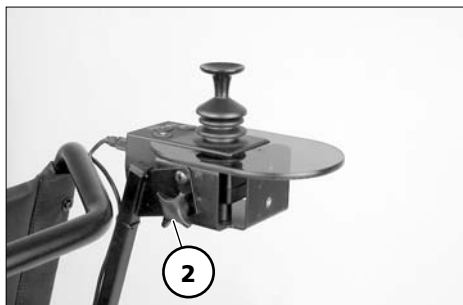
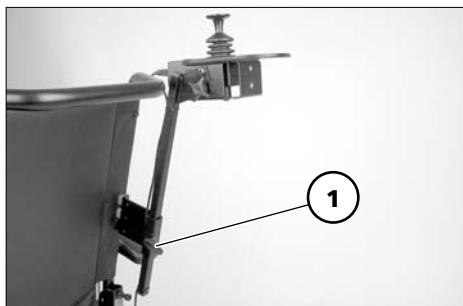

LIGHTING

For driving outdoors and on public roads the electric wheelchair can be fit with LED-lighting equipment.

The lighting is activated over the operating module for the driver.

Note:

Observe the operating manual < *Operating module* > as well as the safety and general handling instructions < *Electric vehicles* >!

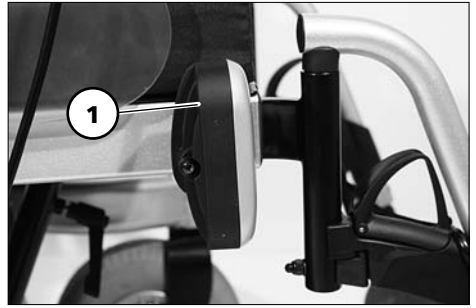

REAR-VIEW MIRROR

Removing the rear-view mirror

To remove the rear-view mirror loosen the clamping screw (2) and pull the rear-view mirror forward out of the arm support tube.

Note:

Carefully place the rear-view mirror down and protect the mirror glass from strain or other objects.

-  The rear-view mirror is to be kept clean at all times.
 - Use common glass cleanser to clean the mirror. For this the users instructions of the manufacturer are to be observed.

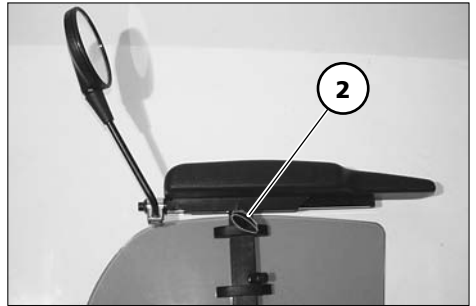

2. Turn the rear-view mirror on the attachment rod and ball joint until you reach the desired angle.

Attaching the rear-view mirror

For drive mode insert the rear-view mirror from the front into the arm support tube and tighten the clamping screw (2).

Adjusting the rear-view mirror

1. Preadjust the rear-view mirror by turning the clasp.

LOADING AND TRANSPORTATION

- ☞ Do not use the back support, leg supports, arm supports or restraints to lift the electric wheelchair!

Attention:

- ! The electric wheelchair must be switched off before lifting!

Loading

The electric wheelchair can be loaded with the aid of ramps or lifting platforms.

☞ **Note:**

Observe safety and general handling instructions < *Electric vehicles* > chapter < *Ramps and lifting platforms* >.

Transport of people inside a motor vehicle

To determine if your electric wheelchair is approved as a seat for person transport inside a motor vehicle, please look at the type plate of your wheelchair.

☞ **Note:**

Observe the guideline < *Safety with Meyra-Ortopedia-wheelchairs, also during transport in motor vehicles* >! – This document and further information can be accessed on our website < www.meyra-ortopedia.com > in the < Download Archive >.

Transport security

The electric wheelchair is only to be secured through the anchoring positions (1)+(3) resp. (2)+(4).

- ☞ The anchor positions are marked with a symbol.
- ☞ The procedure for securing the wheelchair can be read in the document < *Safety and general handling instructions electric vehicles* > chapter < *Transport in motor vehicles or with conveyors* >.

MAINTENANCE

An incorrect or neglected cleaning and maintenance results in a limitation of the product liability.

Maintenance

The following maintenance schedule gives you a guide for carrying out the maintenance.

- ☞ They do not give information about the actual extent of work required on the vehicle.

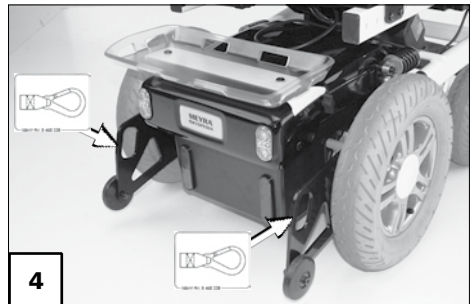
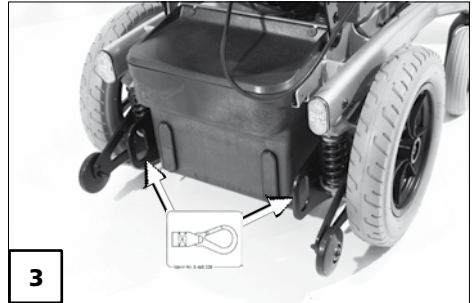
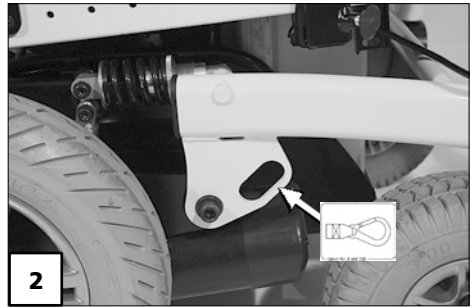
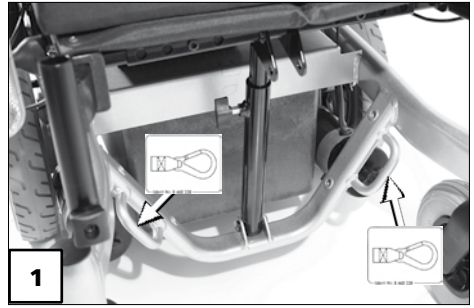

Maintenance schedule

WHEN	WHAT	REMARK
Before starting out	General Test for faultless operation.	Carry out test yourself or with a helper.
	Checking the magnetic brake Move the selection lever for the drive/push mode into the drive mode position on both sides.	Carry out test yourself or with a helper. If the electric wheelchair can be pushed, have the brakes repaired immediately by the specialist workshop. – Danger of accident!
Especially before driving in the dark	Lighting Check the lighting equipment and reflectors for flawless functioning.	Carry out test yourself or with a helper.
Every 2 weeks (depending on distance covered)	Check air pressure of the tyres Tyre filling pressure: 2.5 bar = 36 psi	Carry out test yourself or with a helper. Use a tyre gauge.
	Adjustment screws Screws and nuts are to be checked for tight fit.	Carry out test yourself or with a helper. Retighten the loosened adjustment screws. Contact specialist workshop upon demand.

WHEN	WHAT	REMARK
Every 6-8 weeks (depending on distance covered)	Wheel attachments Wheel nuts or screws are to be checked for tight fit	Do it yourself or with the aid of a helper. Securely tighten any loosened wheel nuts or screws and retighten again after 10 operating hours or resp. 50 km. Contact specialist workshop upon demand.
Every 2 months (depending on distance covered)	Check tyre profile Minimum tread = 1 mm	Carry out a visual check yourself or with a helper. If the tyre profile is worn down or if the tyre is damaged, consult a specialist workshop for repairs.
Every 6 months (depending on frequency of use)	Check – Cleanness. – General condition.	View < <i>Service</i> > in document < <i>Safety and general handling instructions electric vehicles</i> >. Do it yourself or with the aid of a helper.
Manufacturer recommendation: Every 12 months (depending on frequency of use)	Maintenance jobs – Vehicle – Battery charger	To be carried out by the specialist dealer.

Fuses

Replacing the fuses

Before replacing fuses, park the electric wheelchair on a level surface and secure it from rolling away.

☞ Therefore observe chapter < *Securing the electric wheelchair* >.

Attention:

! Only replace the safety fuse with a safety fuse of the same type!

New fuses can be obtained for example at petrol stations.

☞ Note:

If the safety fuse blows again, take the battery to a specialist dealer for repair.

Fuse

Mains-/battery fuse [1]

The blade fuse for the battery current is plugged inside the fuse holder (2) of the battery case.

☞ Please observe the < *Technical data* >!

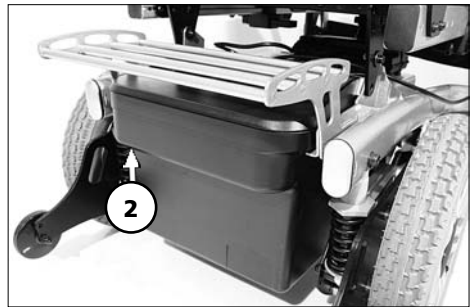
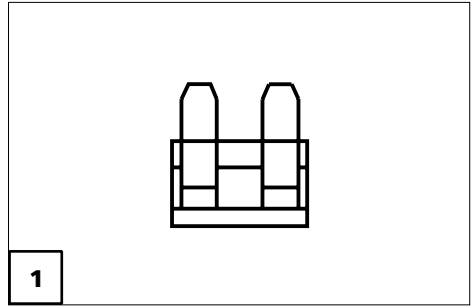

Lighting

The lighting (1)+(2) is equipped with longlife LED-technology.

Note:

If a turn-signal bulb is defective, the remaining one blinks at double frequency.

 Immediately have a defective LED-lamp repaired by a specialist workshop.

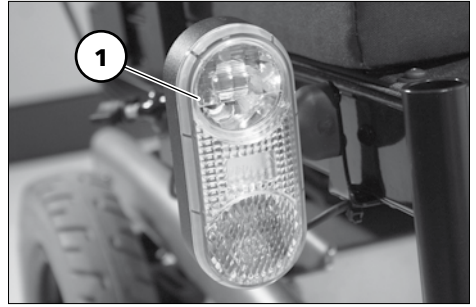

Headlights

The housing of the light (1) must be adjusted so that the light cone is visible on the driving surface. – The lower edge of the light cone should be set at distance of 3 meters to the front of the electric wheelchair.

Note:

 The lighting case might need to be readjusted after adjustment of the seat inclination.

 If needed go to a specialist workshop for adjustment.



Fault correction

Fault	Cause	Remedy
Battery indicator on the operating module does not light up after the switch-on.	Battery fuse is defective or not correctly inserted.	Replace defective fuse or clean contacts and insert correctly.
	Plug connection of the power supply without contact.	Check the plug connections.
The battery indicator blinks after the switch-on.	One or both of the drive motors are switched to push mode.	Move the selection lever for the drive/push mode into the drive mode position on both sides.
	Plug connection at one of the drives without contact.	Check the plug connections.
	Malfunction in the electronics.	Have it repaired by the specialist workshop. (Push mode) Selection lever in driving mode position.
	Not listed faults.	View < <i>Fault diagnosis</i> > in the operating manual for the operating module.
Lighting not active.	LED-lamp defective.	Let it be repaired or replaced by a specialist workshop.
	Lighting fuse or drive electronics defective.	Let it be repaired or replaced by a specialist workshop.

TECHNICAL DATA

Kilometric performance

Kilometric performance depends to a large extent on the following factors:

- battery condition,
- weight of the driver,
- driving speed,
- driving style,
- road surface condition,
- driving conditions,
- ambient temperature.

The nominal values given by us are realistic under the following conditions:

- Ambient temperature of 27 °C.
- 100 % rated drive battery capacity as per the DIN standard.
- new condition of the drive batteries with more than 5 charging cycles.
- Nominal load of 75 kg.
- Without repeated acceleration.
- Level, firm driving surface.

The kilometric performance is greatly reduced by:

- frequent uphill driving,
- insufficient charging condition of the drive batteries,
- low ambient temperature (e.g. in winter),
- frequent starting and stopping (e.g. in town traffic),
- aged, sulphated drive batteries,

- frequently necessary steering manoeuvres,
- reduced driving speed (especially at walking speed).

In practical use, the kilometric performance under 'normal conditions' is then reduced to approx. 80 % – 40 % of the nominal value.

Hill climbing ability

Gradients in excess of the permitted values (e.g. ramps) should for safety reasons only be driven when the wheelchair is empty!

Model 1.610 / 1.611

All data within the following table relates to the standard version of the stated model.

Dimensional tolerance ± 1.5 cm, $\pm 2^\circ$.

Model: **1.610 / 1.611**

Type plate: at the front right on the battery bracket

Class of use as per DIN EN 12184: Class B

Life span: 5 years

Sound level: < 70 dB(A)

Protection class: IP X4

Electrical system:

Drive control 6 km/h: 24 Volt / 70 A max.

Drive control 10 km/h (model 1.611): 24 Volt / 90 A max.

Main fuse: 80 A

Lighting (option): LED-technology 24 V

Dimensions: **min. / max. / manufacturer setting**

Overall length (incl. footplates): 1130 / 1130 / 1130 mm

Overall width:

Model 1.610 (12"-wheels): 590 / 800 / 590 mm

Model 1.611 (12"-wheels): 580 / 800 / 580 mm

Model 1.610 (14"-wheels): 630 / 800 / 630 mm

Model 1.611 (14"-wheels): 620 / 800 / 620 mm

Height (model 1.610): 930 / 1130 / 1010 mm

Height (model 1.611): 930 / 1130 / 1030 mm

front seat height (SH):

Seat belt (model 1.610): 43 / 53 / 48 cm

Seat belt (model 1.611): 43 / 53 / 50 cm

ErgoSeat: SH + 7 cm

Recaro / Basic-Seat: SH + 15 cm

Seat depth (SD): 40 / 56 / 46 cm

Seat width (continuous adjustment over the arm support): 38 / 65 / 43 cm

Seat inclination mechanical: 0° / 10° / 4°

Seat inclination electric: 0° / 26° / 4°

Backrest height:

Standard-/adjustable back support strap (model 1.610):	40 / 50 / 50 cm
Standard-/adjustable back support strap (model 1.611):	40 / 50 / 50 cm
ErgoSeat:	53 / 57 / 53 cm
Recaro:	64 cm
Back support angle mechanical:	-10°/ 30° / 10°
Back support angle electric:	-10°/ 50° / 10°

Back support to front edge of arm support:

with standard-seat belt (SD 46 cm), (min. / max.): 33 / 45 cm

Arm support height from upper edge of seat: 24 / 35 / 26 cm

Lower shank length (LSL), without seat cushion:

Seat belt (min. / max.): 28 / 43 cm

ErgoSeat (min. / max.): 35 / 50 cm

Recaro / Basic-Seat (min. / max.): 35 / 50 cm

Leg support angle adjustable, Code 92/86: 110° to 180°

Wheels:

Steering wheel:

ø 190 x 50 mm (8") pneumatic tyres: (36 psi) max. 2.5 bar

ø 225 x 70 mm (9") pneumatic tyres: (36 psi) max. 2.5 bar

ø 255 x 70 mm (10") pneumatic tyres: (36 psi) max. 2.5 bar

ø 190 x 50 mm (8"): puncture safe

ø 225 x 70 mm (9"): puncture safe

ø 255 x 70 mm (10"): puncture safe

Drive wheel:

ø 320 x 60 mm (12.5 x 2.5") pneumatic tyres: (36 psi) max. 2.5 bar

ø 350 x 75 mm (14 x 3.5") pneumatic tyres: (36 psi) max. 2.5 bar

ø 320 x 60 mm (12.5 x 2.5"): puncture proof

ø 350 x 75 mm (14 x 3.5"): puncture proof

Transport dimensions:

Length (incl. support castors, without leg supports): 830 mm

Width (without arm supports):

Model 1.610 (12"-wheels): 590 mm

Model 1.611 (12"-wheels): 580 mm

Model 1.610 (14"-wheels): 630 mm

Model 1.611 (14"-wheels): 620 mm

Height without arm supports (min. / max.): 570 / 670 mm

(Back support upholstery removed, back support folded onto seat)

Climatic data:

Ambient temperature: -25 °C to +50 °C
Storage temperature with drive batteries: -25 °C to +50 °C
Storage temperature without drive batteries:..... -40 °C to +65° C

Drive batteries, sealed:

Drive batteries (model 1.610):..... 2 x 12 V 38 Ah (5 h) / 45 Ah (20 h)
Drive batteries (model 1.611):..... 2 x 12 V 43 Ah (5 h) / 50 Ah (20 h)
Drive batteries: 2 x 12 V 63 Ah (5 h) / 73 Ah (20 h)
Max. battery dimensions (LxWxH): 26 x 17.4 x 20.5 cm

Range (see Kilometric performance):

45 Ah (20 h) with 6 km/h (model 1.610): approx. 28 km
50 Ah (20 h) with 6 km/h (model 1.611): approx. 30 km
73 Ah (20 h) with 6 km/h (model 1.610): approx. 42 km
73 Ah (20 h) with 6 km/h (model 1.611): approx. 40 km
50 Ah (20 h) with 10 km/h: approx. 25 km
73 Ah (20 h) with 10 km/h: approx. 35 km

Battery charger:

We recommend a charger:

for batteries up to 65 Ah (20 h) 24 V / 6 A
for batteries up to 85 Ah (20 h) 24 V / 8 A
for batteries up to 125 Ah (20 h) 24 V / 12 A
max. charging current: 12 A

Performance - electric (view Kilometric performance):

Forward final speed:..... 6 / 10 km/h
Motor-continuous power rating S1:..... 220 / 300 Watt

Performance - mechanical (view Kilometric performance):

obstacle height upwards:..... max. 60 mm
obstacle height downwards: max. 60 mm
Ground clearance (drive):..... 60 mm
Ground clearance (battery tub):..... 80 mm
Turning radius: approx. 840 mm
Turning area:..... approx. 1300 mm
max. permissible rising gradient: 6° (11 %)
max. permissible falling gradient:..... 6° (11 %)
max. permissible transverse gradient: 6° (11 %)
static tilting safety in all directions: 6° (11 %)

Weights (basic equipment):..... **Model 1.610 / 1.611**

max. permissible total weight: 220 / 280 kg

permitted axle load front: 110 / 140 kg

permitted axle load rear: 150 / (180) kg

Max. permissible user weight:

including additional load: 120 / 160 kg

max. additional loading: 10 / 10 kg

Empty weight (with arm supports and leg supports):

with 45 Ah sealed drive batteries (of 14.6 kg): approx. 94 / 94 kg

with 50 Ah sealed drive batteries (of 21.8 kg): approx. 108 / 108 kg

with 73 Ah sealed drive batteries (of 23.0 kg): approx. 111 / 111 kg

without drive batteries: approx. 65 / 65 kg

☞ *All weight indications are valid for the basic equipment without electric adjustments.*

Arm support Code 106/4960 (pair)3.2 kg

Leg support Code 92/805 (pair)4.0 kg

Leg support Code 93/805 (pair)1.8 kg

Electr. leg support Code 86/805 (pair)9.0 kg

Weight of the heaviest single component:

Leg support (code 86):4.5 kg

Specifics for Seatlift:

Weights: **Model 1.610 / 1.611**

max. permissible total weight: 245 / 280 kg

permitted axle load front: 120 / 140 kg

permitted axle load rear: 160 / (180) kg

Max. permissible user weight:

including additional load: 120 / 140 kg

Empty weight (with arm supports and leg supports):

with 45 Ah sealed drive batteries (of 14.6 kg): approx. 119 / 119 kg

with 50 Ah sealed drive batteries (of 21.8 kg): approx. 133 / 133 kg

with 73 Ah sealed drive batteries (of 23.0 kg): approx. 136 / 136 kg

without drive batteries: approx. 90 / 90 kg

Dimensions: **min. / max. / manufacturer setting**

front seat height (SH):

Front edge seat plate (without seat cushion) (model 1.610): 50 / 53 / 50 cm

Front edge seat plate (without seat cushion) (model 1.611): 51 / 53 / 53 cm

Seat inclination electric: -6° / 30° / 4°

Seat lift (lifting height): 30 cm

Model 1.612

All data within the following table relates to the standard version of the stated model.

Dimensional tolerance ± 1.5 cm, $\pm 2^\circ$.

Model:..... **1.612**

Type plate:.....right on the main frame

Class of use as per DIN EN 12184:.....Class B

Life span: 5 years

Sound level:..... < 70 dB(A)

Protection class: IP X4

Electrical system:

Drive control 6 km/h:..... 24 Volt / 70 A max.

Drive control 10 km/h:..... 24 Volt / 90 A max.

Main fuse:..... 80 A

Lighting (option):.....LED-technology 24 V

Dimensions: min. / max. / manufacturer setting

Overall length (incl. footplates): 1180 / 1180 / 1180 mm

Overall width: 630 / 800 / 630 mm

Height:.....970 / 1140 / 1020 mm

Seat height (with 3.5° seat angle):

Front edge seat plate (without seat cushion):46 / 52 / 49 cm

ErgoSeat: SH + 7 cm

Recaro / Basic-Seat: SH + 15 cm

Seat depth:40 / 56 / 46 cm

Seat width (continuous adjustment over the arm support):38 / 65 / 43 cm

Seat inclination mechanical: 0° / 12° / 4°

Seat inclination electric: -2° / 33° / 4°

Backrest height:

Standard/adjustable back support strap:.....45 / 50 / 50 cm

ErgoSeat:53 / 57 / 53 cm

Recaro:..... 64 cm

Back support angle mechanical:..... -10° / 30° / 10°

Back support angle electric:..... -10° / 50° / 10°

Back support to front edge of arm support:

with seat depth 46 cm:.....33 / 45 / 39 cm

Arm support height from upper edge of seat:24 / 35 / 26 cm

Lower shank length (LSL), without seat cushion:

Seat plate (min. / max.):	28 / 43 cm
ErgoSeat (min. / max.):	35 / 50 cm
Recaro / Basic-Seat (min. / max.):	35 / 50 cm
Leg support angle adjustable, Code 92/86:	110° to 180°

Wheels:

Steering wheel:

ø 190 x 50 mm (8") pneumatic tyres:	(36 psi) max. 2.5 bar
ø 225 x 70 mm (9") pneumatic tyres:	(36 psi) max. 2.5 bar
ø 255 x 70 mm (10") pneumatic tyres:	(36 psi) max. 2.5 bar
ø 190 x 50 mm (8"):	puncture safe
ø 225 x 70 mm (9"):	puncture safe
ø 255 x 70 mm (10"):	puncture safe

Drive wheel:

ø 320 x 60 mm (12.5 x 2.5") pneumatic tyres:	(36 psi) max. 2.5 bar
ø 350 x 75 mm (14 x 3.5") pneumatic tyres:	(36 psi) max. 2.5 bar
ø 320 x 60 mm (12.5 x 2.5"):	puncture proof
ø 350 x 75 mm (14 x 3.5"):	puncture proof

Transport dimensions:

Length (incl. support castors, without leg supports):	870 mm
Width (without arm supports):	630 mm
Height without arm supports (min. / max.):	720 / 840 mm
(Back support upholstery removed, back support folded onto seat)	

Climatic data:

Ambient temperature:	-25 °C to +50 °C
Storage temperature with drive batteries:	-25 °C to +50 °C
Storage temperature without drive batteries:	-40 °C to +65 °C

Drive batteries:

Drive batteries, sealed: 2 x 12 V 43 Ah (5 h) / 50 Ah (20 h)
Drive batteries, sealed: 2 x 12 V 63 Ah (5 h) / 73 Ah (20 h)
Max. battery dimensions (LxWxH): 26 x 17.4 x 20.5 cm

Range (see Kilometric performance):

50 Ah (20 h) with 6 km/h: approx. 30 km
73 Ah (20 h) with 6 km/h: approx. 40 km
50 Ah (20 h) with 10 km/h: approx. 25 km
73 Ah (20 h) with 10 km/h: approx. 35 km

Battery charger:

We recommend a charger:

for batteries up to 65 Ah (20 h) 24 V / 6 A
for batteries up to 85 Ah (20 h) 24 V / 8 A
for batteries up to 125 Ah (20 h) 24 V / 12 A
max. charging current: 12 A

Performance - electric (view Kilometric performance):

Forward final speed: 6 / 10 km/h
Motor-continuous power rating S1: 220 / 300 Watt

Performance - mechanical (view Kilometric performance):

obstacle height upwards: max. 60 mm
obstacle height downwards: max. 60 mm
Ground clearance (drive): 70 mm
Ground clearance (battery tub): 80 mm
Turning radius: approx. 900 mm
Turning area: approx. 1350 mm
max. permissible rising gradient: 6° (11 %)
max. permissible falling gradient: 6° (11 %)
max. permissible transverse gradient: 6° (11 %)
static tilting safety in all directions: 6° (11 %)

Weights (basic equipment):

Max. permissible total weight:.....	320 kg
Permitted axle load front:.....	160 kg
Permitted axle load rear:	220 kg

Max. permissible user weight:

including additional load:.....	160 kg
with seat lift Code 27 (including additional load):	140 kg

Max. additional loading:.....10 kg

Empty weight:

with 50 Ah sealed drive batteries (of 21.8 kg):	approx. 115 kg
with 73 Ah sealed drive batteries (of 23.0 kg):	approx. 118 kg
without drive batteries:	approx. 71.5 kg

🔊 *All weight indications are valid for the basic equipment without electric adjustments.*

Arm support Code 106/4960 (pair).....	3.2 kg
Leg support Code 92/805 (pair)	4.0 kg
Leg support Code 93/805 (pair)	1.8 kg
Electr. leg support Code 86/805 (pair).....	9.0 kg

Weight of the heaviest single component:

Leg support (code 86):.....	4.5 kg
-----------------------------	--------

Meaning of the labels on the electric wheelchair

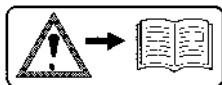

Attention!

Read the operating manuals and other provided documentation.

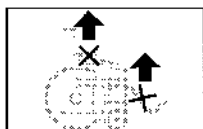

Do not lift the electric wheelchair at the arm supports or leg supports.
Removable parts are not suited for carrying the wheelchair.



Drive mode

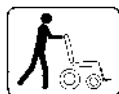

Push mode



Push only on level surfaces.

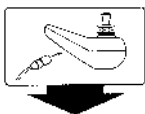

Indication for charging socket

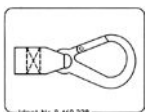

Attachment possibility of the transport securing system.



Indication for danger of jamming. – Do not reach in here

Meaning of the symbols on the type plate



Manufacturer



Order number



Serial number



Production date (Year – Calendar week)



Permitted user weight



Max. permissible total weight

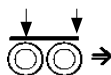

Permitted axle loads



Max. permissible rising gradient



Max. permissible falling gradient

max. ... km/h Max. permitted final speed



The product is approved as a seat within a motor vehicle



The product is **not** approved as a seat within a motor vehicle.

INSPECTION CERTIFICATE

Vehicle data:

Model:

Delivery note no.:

Serial-no. (SN):

Recommended safety inspection 1st year (at least every 12 months)

Stamp of specialist dealer:

Signature: _____

Place, date: _____

Next safety inspection in 12 months

Date: _____

Recommended safety inspection 2nd year (at least every 12 months)

Stamp of specialist dealer:

Signature: _____

Place, date: _____

Next safety inspection in 12 months

Date: _____

Recommended safety inspection 3rd year (at least every 12 months)

Stamp of specialist dealer:

Signature: _____

Place, date: _____

Next safety inspection in 12 months

Date: _____

Recommended safety inspection 4th year (at least every 12 months)

Stamp of specialist dealer:

Signature: _____

Place, date: _____

Next safety inspection in 12 months

Date: _____

Recommended safety inspection 5th year (at least every 12 months)

Stamp of specialist dealer:

Signature: _____

Place, date: _____

Next safety inspection in 12 months

Date: _____

NOTES

WARRANTY / GUARANTEE

We accept legal liability for this product within the scope of our general terms and conditions and warranty and the guarantee according to our described quality service. For warranty and guarantee demands please contact your specialist dealer with following Warranty/Guarantee section and the there included information on model description, delivery note number with delivery date and serial number (SN).

The serial number (SN) can be read off of the type plate.

Precondition for the acceptance of liability in any case is the intended use of the product, the use of original spare parts by specialist dealers as well as maintenance and inspections in regular intervals.

Guarantee is not granted for surface damages, tyres of the wheels, damages due to loosened screws or nuts as well as worn out attachment holes due to frequent assembly work.

Furthermore, damage to the drive and electronics caused by improper cleaning using steam cleaning equipment or the deliberate or accidental flooding of the components are also excluded.

Interferences through radiation sources such as mobile phones with high transmission power, HiFi-equipment and other extreme interference radiators outside of norm specifications cannot be declared as warranty or guarantee claims.

Attention:

- ! Failure to observe the instructions
- in the operating manual, improperly carried out maintenance work and, especially, technical changes and additions (add-ons) carried out without our prior consent will lead to a general loss of guarantee and product liability.

Note:

This operating manual as a part of the product is to be handed out in case of a change of user or owner.

We reserve the right to make technical improvements.



The product conforms with the EC Directive 93/42/EEC (MDD) for medical products.

Warranty / Guarantee section

Please fill out! Copy if necessary and send the copy to the specialist dealer.

Warranty / Guarantee

Model designation:

Delivery note no.:

SN (view type plate):

Date of delivery:

Stamp of the specialist dealer:

Inspection certificate for transfer

Vehicle data:

Serial-no. (SN):

Model:

Delivery note no.:

Stamp of specialist dealer:

Signature: _____

Place, date: _____

Next safety inspection in 12 months

Date: _____



┌ Your specialist dealer: ┐

└

└

MEYRA®
ORTOPEDIA

We move people.

MEYRA-ORTOPEDIA
Vertriebsgesellschaft mbH
Meyra-Ring 2 · D-32689 Kalletal-Kalldorf
P.O. Box 1 703 · D-32591 Vlotho
Fon +49 (0)5733 922-311
Fax +49 (0)5733 922-9311
info@meyra-ortopedia.de
www.meyra-ortopedia.de

205 338 101 • (Status: 2012-09) Original operating manual! Subject to technical modifications!